

Design and Fabrication of Vertical Axis Highway Windmill

S. V. Saravanan, M. Varatharaj, L. Ayyadurai, S. Palani & D. Prem

Christ the King Engineering College, Tamilnadu, India.

E-mail : Coimbatoreprincipal@gmail.com, Varatharaj_ms80@rediffmail.com, Ayyadurai17@gmail.com, palanimani006@gmail.com, dprem93@gmail.com

Abstract – In today's life the demand on electricity is much higher than that of its production the main objective of our project is to produce electricity by using the force of air created by the moving vehicle in highways. In highways the vehicle suffers a lot to travel in night time because of lightning problem. This problem can be overcome by using the VERTICAL AXIS HIGHWAY WINDMILL (VAHW). This is a new unique method of power generation. In this method the windmill blade is designed in a vertical direction and it is kept at the middle of the highway divider by a series combination. The force in the middle portion is higher than the side of the road. This force will rotate the vertical turbine blade. And this blade is coupled with the generator and this generator will produce electricity. In our method we have coupled one more generator and we have increased its efficiency.

Keywords – DC generator, coupling pipes, blades, pipes.etc.

I. INTRODUCTION

In today's scenario the world have been developed by the technologies like microcomputer, 3G, 4G devices, sixth sense devices etc. By using these we can communicate from any corner of the world. if we think which leads this technology development means the solution takes us to the root and say's 'Energy' .so without energy nothing will move in this world

In this 21 st century there are more methods to produce energy. Some of them are ecofriendly and some of them might be pollutable. Once we aim to produce energy by ecofriendly means the best idea is by using renewable energy. In renewable energy field sector the windmill plays an important role in energy production.

The present design of windmill might not be implemented in our normal surroundings. As it is not

suitable for all wind direction and it gives partial efficiency and also increase in cost of design, installation, and maintenance. To overcome all these problems an new unique method of wind is to be introduced. This paper have kept one step forward of windmill technology with use full application.

The main aim of this project paper is to produce energy by using renewable energy resources in that manner the wind is very much eco friendly and very compactable one. By using that energy in a useful manner we can produce a continuous power .

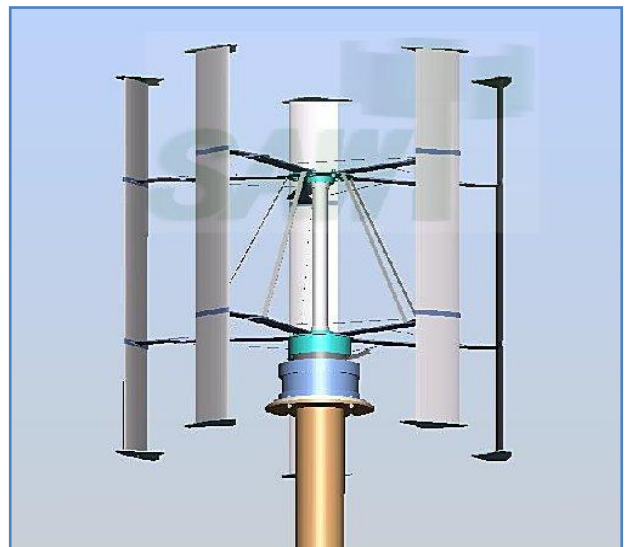

STRUCTURAL DIAGRAM

Fig .1

This VAHW is a new method which overcomes the previous windmill problems. By adjusting the windmill blade it suit itself with efficient energy generation in all direction

The main advantage of VAHW is it can generate power in all direction of wind flow. And the other advantages are the maintenance are less and the height of the tower is less.

II. PRINCIPLES OF WIND ENERGY CONVERSION

The primary component of a wind turbine is the energy converter which transforms the kinetic energy contained in the moving air, into mechanical for the initial discussion of principle, the exact nature of the energy concur is irrelevant the extraction of mechanical. Energy from a stream of moving air with the help of a disk shaped rotating wind energy converter follows its own basic rules. The credit for having recognized this principle is owed to Albertbetz. Between 1922and 1925. Betz published writings in which he was able to show that by applying elementary. Physical laws the mechanical energy extractable from air stream passing through a gives cross section area is restricted to a certain fixed proportion of the energy or power contained in the air stream .moreover ,he found that optimal power extraction could only be realized at a certain ratio between the flow velocity of air in front of energy converter and the flow velocity behind the converter all through BETZ .momentum theory which assumes the energy converter working without losses in a fraction less air flow contain simplification if results air quite usable for performing rough calculation in practical engineering .but it is true signification if founded in the fact that if provides common physical basis for the understanding and operation of wind energy converters of various design

III. ELEMENTRY MOMENTUM THEORY

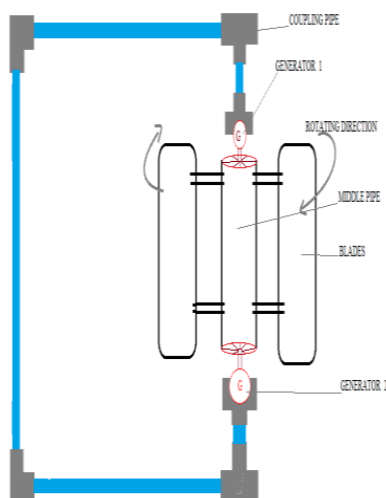

SCHEMATIC DIAGRAM OF VAHW

Fig.2

The kinetic energy of an air mass m moving at a velocity v can be expressed as

$$E = \left(\frac{1}{2}\right)mv^2Nm$$

Considering a certain cross-sectional area although which the air passes at velocity V , the volume v' flow through during a certain time unit, the so called volume flow is

$$V' = VA\left(\frac{m^3}{s}\right)$$

IV. DESIGNING METHODOLOGY

This design methodology is to increase the efficiency of the windmill at first the designing steps starts with the design of windmill blades. Because this blades will mainly affects the overall efficiency of the windmill. For a particular application the wind mill blade should be in required size. Before this getting knowledge about the aerodynamic style of windmill blade in order to get the full efficiency is very much important.

The various considerations are.

A. Wind speed:

The speed of the wind is very much important for the production of electricity in the windmill. Because in windmill we are using the wind as a raw material for the power production .this bakes the axis rotate and this axis is coupled with a dc generator and makes its also rotate and produce electricity.

B. Tower height and design:

The height of the tower is very much important for a windmill. In VAHW the tower is kept little sort to obtain whole air density passing from the vehicle.

We also should concentrate in the design of the tower because it should able to withstand for its own weight and also in the speed of the wind

C. Shape of the blade:

As discussed earlier the shape of the wind mill blades is the important one if one could place an efficient design of a blade then the efficiency of the windmill will be increased.

The various windmill shapes are as follows;

- Flat, unmodified blade surface.
- wing shape with one leading edge

- c) Both edges tapered to a thin line.
- d) Both edges leading blade

A drawing of tested shape blades are provided below;

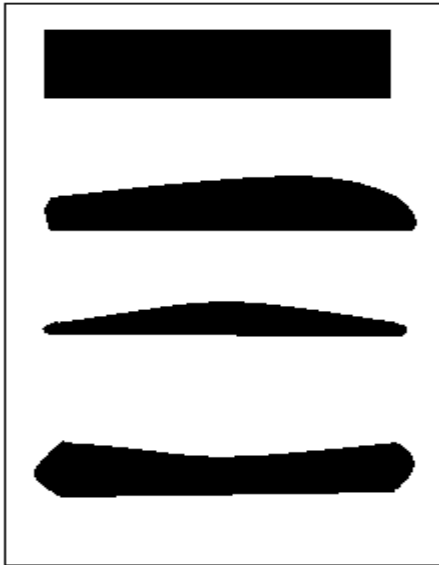

VARIOUS SHAPE OF BLADES

Fig.3

D. Tip speed ratio:

This tip speed ratio defines the speed of the wind that hit the tips of the blades and makes a rotation. In this speed the blade will give you a good performance. When the tip speed ratio increases the productivity of the windmill also increases.

V. AERODYNAMICS CONCEPT

This aerodynamic concept shows the forces and velocities cutting in a turbine. The resultant velocity vector, W' is given by

$$W' = U' + (-w' * r')$$

Where,

U' - undistributed upstream air velocity

$(-w' * r')$ - velocity vector of advancing blade.

Thus the oncoming velocity varies, maximum is found for $\theta = 0^\circ$ and the minimum is found for $\theta = 180^\circ$ where θ is the azimuthal or orbital blade position. The angle of attack α is the angle between the oncoming air speed.

$$\alpha = \tan^{-1} \left(\frac{\sin \theta}{\cos \theta + \gamma} \right)$$

Here

$$\gamma = \frac{\omega R}{U}$$

W , and the blade cords, the resultant airspeed flow and the angle of attack are calculated as follows:

$$W = U \sqrt{(1 + 2\gamma \cos \theta + \gamma^2)}$$

The blade turbine must place according to aerodynamic concept. All the variables related to this model definitely varies according to the environment in which it is going to be installed

VI. DESIGN OF BLADES

For the design of blades the selection material is very much important. Because the material that we are selecting should be more weight less and it should be able to withstand at high air pressure. For that a special grade of aluminum metal can be used it has light weight and it can be able to withstand at high air pressure. The next important thing is to choose a blade shape.

The c-type blade is suitable for vertical axis highway windmill (VAHW). Because its shape can be able to collect maximum air pressure and it can be able to give maximum energy transformation from forced wind energy to rotational mechanical energy. The shape of the blade used is shown below

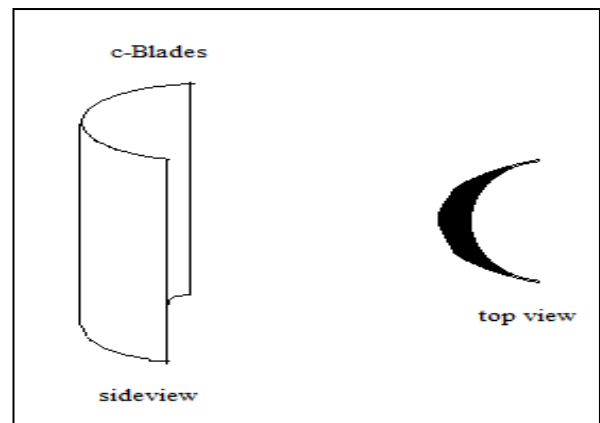

Views Of Blade

Fig.4

In vertical axis highway wind mill normally have four c-type blades that are placed in vertical direction.

These four blades have normally separated by 90-degree angle with each other. So that in highways when vehicle passes the VAHW will rotate in clockwise direction..

The wind turbine blade design has been decided and now the blades must be fixed to built the turbine the arrangement of blades and its rotating directions are shown in below diagram

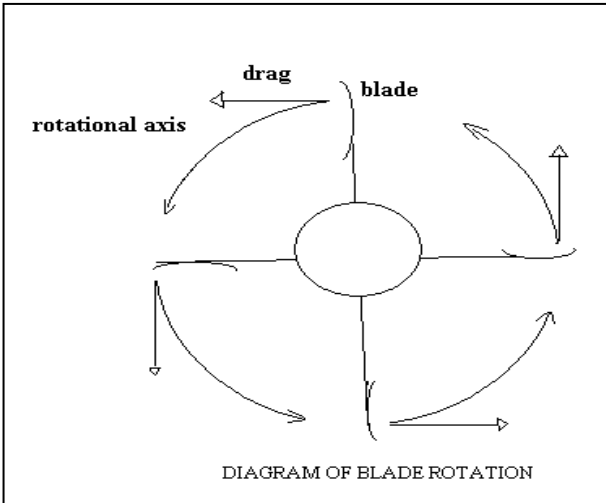

Fig. 5

VII. DC GENERATOR IN VAHW

The alternators or generators are the heart of the windmill and it must be properly sized to match your swept area and to produce right type of power to match your application. The unit needs to make higher voltages at lower rpms, otherwise it is not suited for wind power use, even motors can also be used as generators. In this vertical axis highway windmill we are using two dc generators coupled with the wind blade turbine.



Normal Generator

Fig.6

Wind generators come in various voltages such as 12volts, 24volts and 48volts DC and in a range of currents up to 80amps at 12volts. The wind generator is a square torque machine and the output increases exponentially with increasing wind speed. Most quality wind generators come with a blade stall facility that “stalls” the blades at high wind speed. Available also is an electrical blade lock that locks the generator on the throw of a switch. This prevents the generator turning when servicing is in progress.

Wind generator technology is very mature technology and has been used by yachtsmen for at least the last 20 years. The technology is reliable and reasonable priced.

Maintenance of a wind generator is simple, just grease the front and rear bearings and check all bolts and connections on a basis

Wind generators are capable of producing large amounts of current, up to 80amps at 12volts and should always be fitted with a charge controller containing a power dump system.

Wind Generators are a cost efficient way of producing power using a sustainable energy force the wind. They indicate easily into an Hybrid Power System and work well with solar arrays. The solar array controller can also be used by the wind generator to control and dump any excess power produced by the hybrid system. If the sun does not shine hopefully the wind will be blowing yearly

a) start up speed:

This wind speed at which the rotors starts turning. It should spin smoothly and easily when you turn it by hand, and keep spinning for few seconds. Designs that ‘cog’ from magnetic force or that use gears or pulley to increase shaft speed will be poor at start up. A good design can start spinning in 5 mph winds cut in at 7 mph.

b) Inefficiency :

Every generator has a certain speed at which it runs most efficiently. But since the wind is not constant, we must try to design to happy medium. As the wind speed rises, the raw power coming into the generator from the wind becomes more than the generator can effectively Use, and it gets more and more inefficient. This power is wasted as heat in the stator coils.

VIII. OPERATION EXPLANATION

This verticle axis highway windmill is placed in the highway dividers. When the air is forced by passing the vehicle from both sides the speed of a wind at the center place is higher than the pedestrain walking lane.

This wind make the VAHW to rotate at high speed and it is coupled to generator to produce electricity and the power can be stored in the battery and it is utilised at the night time

BLOCK DIAGRAM OF VAHW:

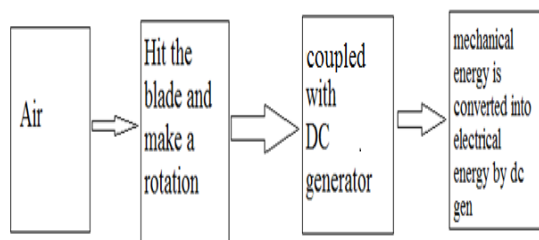

This energy conversion process is explained by several following steps:

Step-1:

In the first step the forced wind and middle part of the highway will hit wind turbine blades and make a rotation in it. The wind turbine blade will rotate in clockwise direction even when the vehicle moves in any of the side of the highway, because of the arrangement of the wind turbine blades in that manner.

Step-2:

The vertical axis highway windmill the wind blade turbine is coupled with the two generators. One is at the top and the other one is at the bottom of the wind turbine blades. When the turbine blade rotates, the coupled generators will produce electricity in both directions.

Step-3:

Thus the mechanical energy is converted into electrical energy by using a DC generator and this produced power is stored in the battery and is utilized by application wise.

IX. PROTOTYPE MODEL



Fig.7

We have done a prototype model of this project. In that prototype model we have used only PVC pipes and silver plates. The wind turbine is made by 5" PVC pipe and we made shaft by using 1.5" pipe and we fix silver plates as a blade. We have used only a DC motor instead of a DC generator. The two motors are coupled at the top and bottom of the wind turbine. We use a gear pulley to increase the RPM of the motor shaft and increase its RPM and makes it to generate and the output of the motor is connected to the power LED with the range of 6V to 9V. The prototype model is shown in the above figure.

X. CONCLUSION

This vertical axis highway windmill gives an idea about the new way of power generation and also about the new windmill technology. The power generation using VAHW is an ecofriendly method and power produced here is almost a continuous one. By using this technology all the highways can be lightened without use of non-renewable energy resources. And if this method is implemented in all national highways we can be able to produce large amount of power and it can also provide job for many educated fellowships.

XI. FUTURESCOPE DEVELOPMENT

- By fixing solar panel in this VAHW will increase the efficiency.
- Fixing more in series or in parallel manner will give more efficiency.

XII. ACKNOWLEDGMENT

We express our sincere thanks to Dr.S.V.Saravanan, principal and Mr.M.Varatharaj Asst.prof & HOD and my Department staff members, Department of Electrical and Electronics Engineering, Christ The King Engineering College, Coimbatore.

XIII. REFERENCES

- [1] J.G Leishman challenges in modelling the unsteady aerodynamics of wind turbine.
- [2] Wind power plant and project development-joshua earnest
- [3] www.scribd.com
- [4] Images taken from <http://www.alternative-energy-news.info/vertical-axis-windmill/>
- [5] IEEE research paper of highway windmill.

