



# Performance analysis of CDMA rake receiver with PIC for wireless communications

<sup>1</sup>B.Sravana Kumar, <sup>2</sup>R.S.Rao

<sup>1</sup>M.tech Student, sree vidyanikethan engineering college, A.P, India

<sup>2</sup>professor, Dept of ECE, sree vidyanikethan engineering college, A.P, India

**Abstract-** In this paper, a software wireless communication simulator performed which simulates a Code division Multiple Access (CDMA) as Wireless cellular telephony has been growing at a faster rate than wired-line telephone networks. This growth has also been fueled by the recent improvements in the capacity of wireless links due to the use of multiple access techniques (which allow many users to share the same channel for transmission) in association with advanced signal processing algorithms. The simulator is a tool to evaluate these design opinions and trades in different scenarios. An efficient method of system is used to speed up the simulations. The simulator can be used to study the performance of a CDMA with variation in system parameters and channel conditions. In this simulator we change the attenuation factor and simulate CDMA with RAKE receiver and without RAKE receiver. Furthermore, we will compare the BER in received data with and without RAKE receiver and also using PIC technique to eliminate further multiple access and multipath interference to improve the performance of the rake receiver.

**Keywords:** CDMA(code division Multiplexing), DS-SS (Direct Sequence Spread Spectrum), FDMA (Frequency division Multiplexing), Parallel interference Cancellation (PIC), BER (bit error rate), RAKE receiver.

## I. INTRODUCTION

Wireless cellular telephony has been growing at a faster rate than wired-line telephone networks. This growth has also been fueled by the recent improvements in the capacity of wireless links due to the use of multiple access techniques (which allow many users to share the same channel for transmission) in association with advanced signal processing algorithms [1]. Code division multiple access (CDMA) is becoming a popular technology for cellular communications due to its superior capacity and performance. Unlike other multiple access techniques such as Frequency Division Multiple Access (FDMA) and Time-Division Multiple Access (TDMA) which are limited in frequency band and time duration respectively, One of the main advantages of CDMA system is the capability of using signals that arrive in the receiver with different time delays this Phenomenon is called multipath. Whereas CDMA uses all of the available time-frequency space.

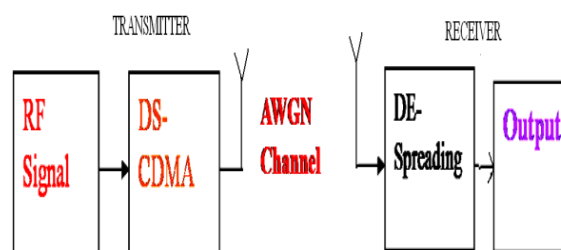

Fig 1: simple Block Diagram of DS-CDMA Transmitter and Receiver.

In CDMA spread Spectrum systems, the chip rate is typically much greater than the flat fading bandwidth of the channel. Whereas Conventional modulation techniques require an equalizer to undergo ISI between adjacent symbols, CDMA spreading codes are designed to provide very low correlation. Thus, Propagation delay spread in the radio channel merely provides multiple versions of the transmitted signal at the receiver. If these multipath components are delayed in time by more than one chip duration they appear like uncorrelated noise at a CDMA receiver, and Equalization is not required. Among Different forms of CDMA a Direct Sequence CDMA (DS-CDMA) uses a set of unique signature sequence or spreading codes to modulate the data bits of different users [2-3]. Direct Sequence (DS) Spread Spectrum is often claimed to have particular properties that makes it less vulnerable to multipath reception. Parallel interference cancellation (PIC) technique reduces the degradation effect of the user interference but with lesser implementation complexity the technique operates on the fact that parallel processing simultaneously removes from each user the total interference produced by the remaining most reliably received users accessing the channel.

## II. RAKE RECEIVER:

In multipath channel, delayed reflections interference with the direct signal in a DS-CDMA can be detected by rake receiver, a RAKE receiver technique which uses several baseband correlators to individual process several signal multipath components. The correlators are

combined to achieve improved communications reliability and performance [4].

RAKE receiver, used specially in CDMA cellular systems, can combine multipath components, which are time-delayed versions of the original signal transmission. Due to reflections from obstacles a radio channel can consist of many copies of originally transmitted signals having different amplitudes, phases, and delays, a RAKE receiver can be used to resolve and combine them. This combining is done in order to improve the signal to noise ratio (SNR) at the receiver. RAKE receiver attempts to collect the time shifted versions of the original signal by providing a separate correlation receiver for each of the multipath signals. The RAKE receiver uses a multipath diversity principle. It is like a rake that rakes the energy from the multipath propagated signal components [5].

The RAKE receiver consists of multiple correlators in which received signals are multiplied by time shifted versions of a locally generated code sequence. The intention is to separate signals such that each finger only attain signals coming in over a resolvable path. The spreading code is chosen to have a very small autocorrelation value for any non-zero time offset that avoids crosstalk between fingers. It is not a full periodic autocorrelation that determines the crosstalk between signals in different fingers, but rather two partial correlations with contributions from two consecutive bits or symbols [6]. It has been attempted to find sequences that have satisfactory partial correlation values, but the cross talk due to non periodic correlations remains substantially more difficult to reduce than the effects of periodic correlations the rake receiver is designed to optimally detect as DS-CDMA signal transmitted over dispersive multipath channel.

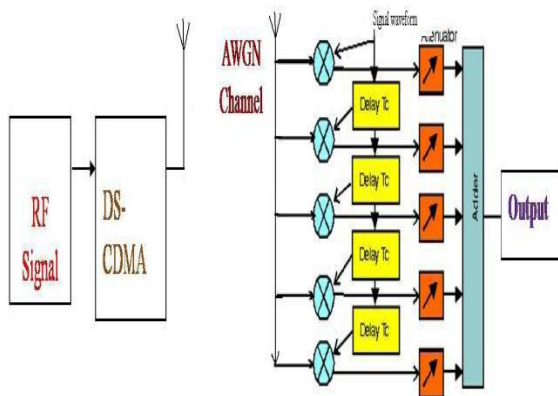

Fig 2: Simple Block Diagram of DS-CDMA with RAKE Receiver.

Like a garden rake, the rake receiver gathers the energy received over the various delayed propagation paths. According to the maximum ratio combining principle, the SNR at the output is the sum of SNR's in the individual branches, provided that, We assume that only AWGN channel is present and codes with time offset are truly orthogonal.

### III. PURPOSE OF WORK

The objective of the work is to simulate and evaluate the performance of different parameters and RAKE receiver performance for CDMA. This work will provide crucial information leading to the implementation of CDMA simulator in the real world system. RAKE was used in this work along with receivers that used the information in channel. For both RAKE and without RAKE, we compare them in multipath environment. It will be shown that the use of number of bit error in the received data by the RAKE receiver is less than the received data without RAKE receiver. In order to suppress the multipath interference (MPI) and multiple access interference (MAI) in DS-CDMA system a RAKE receiver based on the parallel interference cancellation (PIC) used in this work [7]. RAKE receiver performance can be increased greatly by using PIC method with simple implementation. The multipath link developed in the software simulation system is intended as a backbone for developing more complex systems. This exible link has a multipath interface which allows a system design to test different scenarios by changing the parameters (such as number of users, paths, channel properties and attenuation factor) [8]. The modular design of the simulation system allows easy addition of algorithms to library.

#### A. RAKE receiver based on PIC:

When the Signal through the wireless channel, it will produce multiple path fading inevitably [9]. The effects of multiple path interference to the receiver in spread spectrum communication and discussed some anti-interference techniques. The common methods Used to suppress the multiple path interference have as the back detected progression and the Rake receiver etc. In the DS CDMA systems, the time domain Rake receivers are used to distinguish, correct and combine different time delay multi-path signal so the inter-symbol interferences are overcome and the path diversity is obtained. By the signal energy of the every path, the Rake receiver obtains diversity gain and as an effective anti multi-path technique, it has become the non-absent key technique in the Third Mobile Communication. Meanwhile, because of the multi-path transmission in channels, multi-path interferences exist between different paths in the identical user [10]. Especially, when the self-correlation between spread codes is worse, the performance about conventional IC Rake receiver will degrade. Based on the research, a new parallel interference cancellation method is proposed in this paper in order to eliminate further multi-access and multi-path interference and improve the performance of the Rake receiver in CDMA systems.

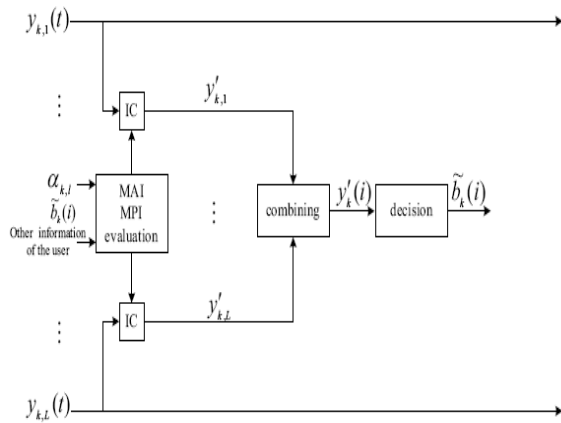

Fig 3: RAKE Receiver with PIC.

It can be proved that the interface estimators estimate MAI and MPI of each channel path according to tentative test value and other known user information (as spread codes of other users, signal amplitudes...etc) in the interference cancellation stage and subtract them then the correlated outputs after interference cancellation for each path are combined finally [11]. Some of Basic expressions used while PIC is given below,

1. The Eq (1) represents reshaping of the transmitted bits from generation of base band signal for kth user.

$$Md = \text{reshape} \left( Md, \left[ n_{rx}, n_{tx}, \frac{N}{n_{tx}} \right] \right); \text{----- Eq (1)}$$

2. The Eq (2) represents the generation of randomly the channel co-efficients in order to transmit the data bits over a channel.

$$h = \frac{1}{\sqrt{2}} * \left[ \begin{matrix} \text{randn} \left( n_{rx}, n_{tx}, \frac{N}{n_{tx}} \right) + \\ j * \text{randn} \left( n_{rx}, \frac{N}{n_{tx}} \right) \end{matrix} \right] \text{-- Eq (2)}$$

3. The Eq (3) represents the original data transmitted over channel along with added noise signal .where, n represents the noise signal and h is the channel coefficients.

$$y = \text{squeeze} \left( \text{sum} (h * Md, 2) \right) + 10^{\frac{EBNo(ii)}{20}} * n \text{--Eq (3)}$$

Whereas the RAKE receiver performance can be increased greatly by using PIC method with simple implementation and BER decreases compared with the Conventional IC.

#### IV. SIMULATION RESULTS AND ANALYSIS

In this project we will show the transmit data and received data on different attenuation factor and number of bit error also shown in GUI, this project show that the number of bit error in received data with the RAKE receiver is less than the number of bit error in the received data without RAKE, and when we increase the attenuation factor the number of bit error is decreased.

The also the output without GUI for the RAKE receiver is also shown and also in order to increase the performance of the RAKE receiver a new parallel interference cancellation method utilized to eliminate MAI and MPI compare to Conventional IC and also shown PIC RAKE receiver output plot for different paths. It is easy to explore and find your way around the system using a GUI.

#### A. GUI for DS-CDMA simulation without RAKE

When we push the push button simulation without RAKE button with attenuation factor 7 then the transmitting data and receiving data, no. of bit error and multipath receiving data from different number of users all shown in fig 4.

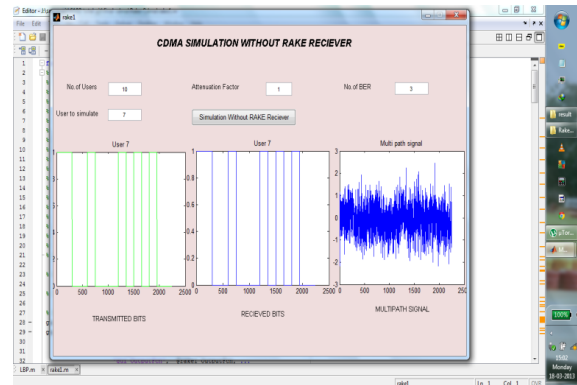

Fig 4: GUI for DS-CDMA simulation Without RAKE receiver.

#### B. GUI for DS-CDMA simulation with RAKE

When we push the push button simulation with RAKE button with attenuation factor 7 then the transmitting data and receiving data, no. of bit error and multipath receiving data from different number of users all shown in fig 5. BER is ZERO for attenuation factor 7.

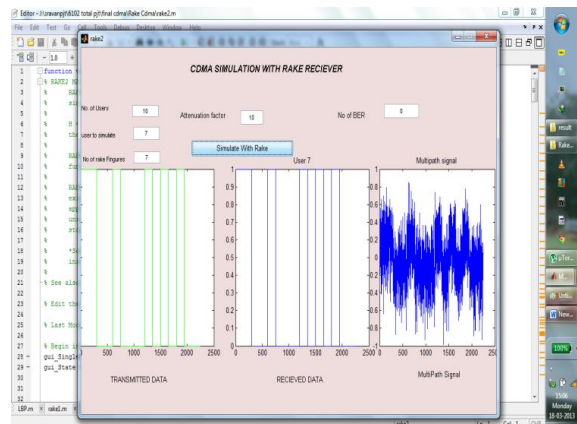

Fig 5: GUI for DS-CDMA simulation With RAKE receiver.

#### C. Output of DS-CDMA RAKE receiver

By using RAKE receiver from the graph it is observed that as BER decreases there is an increase in SNR as shown in fig 6. This is desired for an efficient communication system.

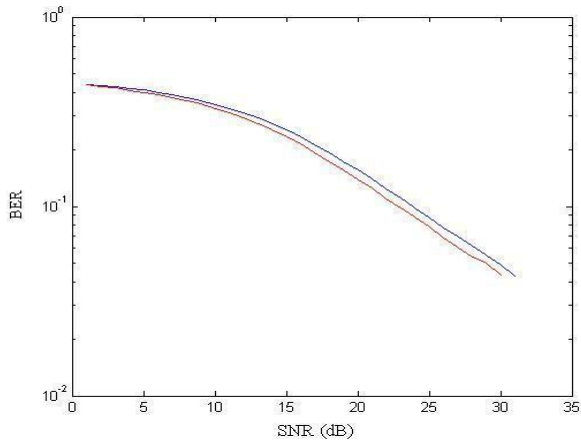

Fig 6: DS-CDMA simulation With RAKE receiver.

#### D. Conventional IC and PIC Performance Comparison using RAKE receiver

In this section, the simulation results have been given in Fig.7 and Fig.8. The PIC shows superior performance than Conventional IC, especially, the PIC system Proposed in this paper appears the best performance.

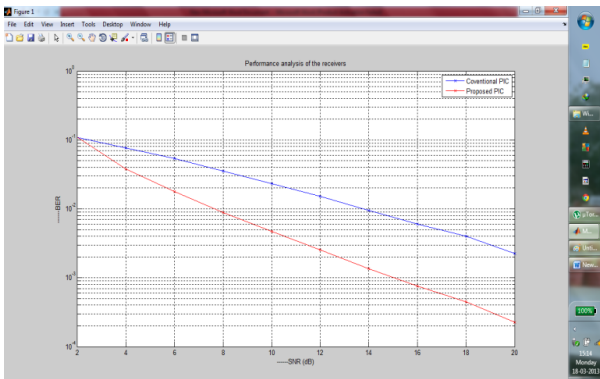

Fig 7: BER Vs SNR for performance Comparison of Conventional IC and PIC with RAKE receiver.

In Fig 8, the bit-error-ratios (BER) of the system for different path numbers are compared.

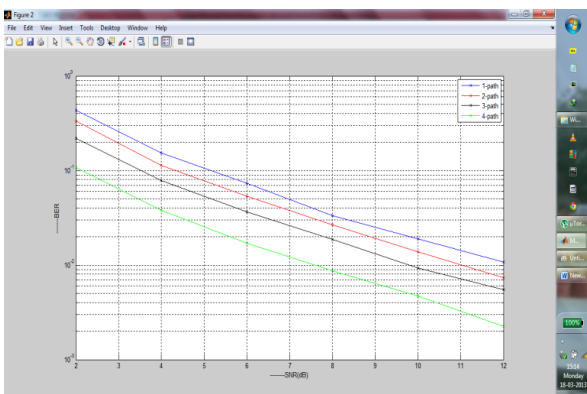

Fig 8: BER Vs SNR performance of RAKE receiver.

## V. CONCLUSION

In this paper, we have shown that how the rake receiver is used in CDMA to decrease BER due to multipath

interference and also a PIC based RAKE receiver in order to suppress the multipath interference (MPI) and multiple access interference (MAI) in DS-CDMA system. In this simulator we can change the attenuation factor and simulate CDMA with RAKE and without RAKE receiver, we have compared the bit-error-ratios (BER) of the system for different path numbers over RAKE Conventional IC and RAKE PIC in order to provide best performance for communication system. It shows that RAKE based PIC is best.

## ACKNOWLEDGEMENTS

The authors like to express their thanks to the department of ECE and management of sree vidyanikethan engineering college for their continuous support and encouragement during this work.

## REFERENCES

- [1] Esmael H.Dinan and Bijan jabbari "Spreading codes for Direct sequence CDMA and wideband CDMA cellular Networks" IEEE communications magazine, Sep 1998.
- [2] Peter Flanagan, "Personal Communications Services: The Long Road Ahead," Telecommunications, February 1996.
- [3] P. Jung, P. W. Baier, and A. Steil, "Advantages of CDMA and Spread Spectrum Over FDMA and TDMA in Cellular Mobile Radio Applications," IEEE Transactions Vehicular Technology, Vol. 42, no. 3, pp. 357- 364, August 1993.
- [4] Tommi Heikkila, "RAKE Receiver", Postgraduate Course in Radio Communications, autumn 2004.
- [5] Mohammad Farukh Hashmi and Pradeep Dhakad "Design and Analysis of DS-CDMA RAKE Receiver Simulator for Wireless Communication", IEEE 2011.
- [6] <http://wireless.per.nl/reference/chaptr05/cdma/rake.htm>.
- [7] Marco Michellini, Enrico Del Re, "A Selective Parallel Interference Cancellation Receiver to mitigate Multiple Access Interference in a MC-DS/CDMA system", 50139 Firenze.
- [8] P. Patel and J. Holtzman. "Performance Comparison of a DS/CDMA System using a Successive Interference Cancellation (IC) Scheme and a Parallel IC Scheme under Fading," IEEE Journal on Selected Areas in Communications 1, 58-67.
- [9] K. R. Shankar Kumar and A. Chockalingam "Parallel Interference Cancellation in Multicarrier DS-CDMA Systems ", IEEE Transactions 2004.

- [10] Zhanyun Duan, Tobias Hidalgo Stitz, “Performance Analysis of Parallel Interference Cancellation Detector In Downlink MC-CDMA Systems”, Proceedings of the 6<sup>th</sup> Nordic Signal Processing Symposium - NORSIG 2004.
- [11] Li-xin Song, zheng-qiang Wang, xiao-bo Li “A New Parallel Interference Cancellation Algorithm for RAKE systems”, IEEE transactions 2009.

