



The Smart Village Electronic Model

Puja Deokate, Puja Kedar, Yogesh Shinde, M. M. Dhanvijay

Department of Electronics and Telecommunication, Modern education Society College of engineering, Pune - India
Email: ¹yogiraj1713@gmail.com, ²pujadeokate123@gmail.com, ³puja.kedar96@gmail.com

Abstract : This paper describes the on-going work of smart Village Electronic Model as a final year project in Modern College of Engineering, Pune. The aim of this project is to minimize or reduce the problem we are facing in today's world such as pollution, drought, global warming, deforestation using smart technology grid. There are many crises in today's world, we are trying to solve those using different technology. We will represent a model of smart village. The successful combination of smart processes and technologies will enable energy efficiency and savings to be achieved in the residential and business markets. Intelligent systems and integrated communication infrastructure are highly demanded, which can assist in the management of power distribution grids in an optimised way. Not only the energy conservation but the water resources conservation is also the motto behind our project.

We are using line follower robot as a smart vehicle and water level indicator as well as an amphibian robot. We can modify it with adding other projects also like garbage monitoring system, solar tracking system, traffic light controlling etc.

Keywords—PIC controller; LED-LDR; DC Motor; L293D Motor Driver IC; RF Transmitter Receiver Model; BLDC Motor; DC Motor

I. INTRODUCTION



Fig.1 Model

As you can see in above fig we were going to make such a model for our project. It consists of smart vehicle, Amphibian robot, water level indicator, and many other small electronic projects etc. Smart vehicle is nothing but simply a line follower robot which follows white track or black track depends on programming. Smart vehicle is used for making transportation smarter and efficient it also helps to minimize pollution. Amphibian

robot is the robot which can run on the any type of surface as well as it can float on water surface and also it can fly. We are using amphibian for monitoring purpose and for collection of data about forestation/deforestation also it can collect information about available water resources. Amphibian robot can be used while making or designing the plans for villages/cities. We are using water level indicator for monitoring water levels in dams. The other parts we are using are electric water pump using dc motor and many more small projects we are going to use here.

II. BLOCK DIAGRAM:

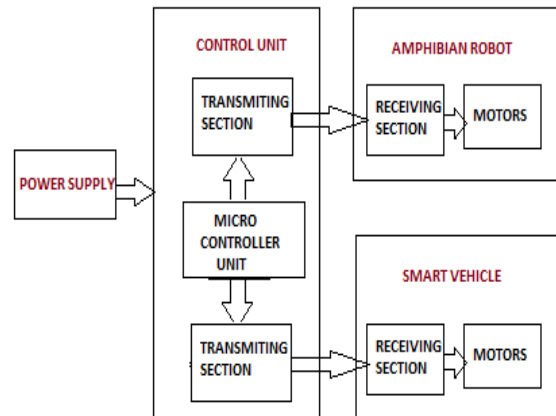

Fig.2 Block diagram of smart Village

1) WATER LEVEL INDICATOR:

Water level indicator is used here for dam water level indication and flow control. It consists of following blocks and hardware's:

- a) Input sensors- simply a wires
- b) Switching circuitry- transistors Bc547
- c) Indicators : LED's and Buzzer.



Fig. 3 water level indicator

a) Input sensors:

The input sensor should be moisture sensor or any other sensor but we are using here conducting wires.

b) Switching Circuitry:

Here we are using transistor as a switch. BC547 transistor is used for switching purpose. The conducting wires are connected to its base terminal and indicators are connected to its emitter terminal.

c) Indicators

The indicators are LED's, Buzzers etc. Different color LEDs and A Buzzer is used as an indicator.

2) SMART VEHICLE:

The line follower robot is used as a smart vehicle, it consists of following blocks:

- a) Power supply
- b) Sensors
- c) Control unit
- d) Motor driver

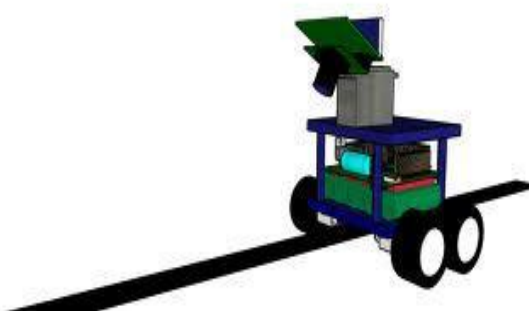

Fig. 4 line follower Robot

a) Power supply:

We are using 12v for motors and 5v for controller. For that we are using 12 v dc battery and taking 5v from battery using 7805 voltage regulator ic.

b) Sensors:

The LED and LDR is used as a sensor and making a sensor circuit with timer ic NE555.

c) Microcontroller unit

Here we are using PIC16F877 Microcontroller. The DC motors are interfaced with the microcontroller by using motor driver ic.

d) Motor driver:

We are using L293D motor driver ic for interfacing DC motors with the microcontroller. It requires 12v dc for its operation.

3) AMPHIBIAN ROBOT:

Here we are using RC see plane as an amphibian robot, it can fly as well as float on water surface, it has following blocks:

- a) RF transmitter and receiver
- b) Power supply
- c) Motors
- d) Propellers



Fig. 5 sea plane as an amphibian robot

a) RF transmitter and receiver:

The RF transmitter and receiver having frequency of 2.4GHz used for our sea plane or an amphibian robot.

b) Power supply:

We are using Li-Po batteries for our plane.

c) **Motors:**

We are using single BLDC motor for take of the plane and for providing direction we are going to use a servo motor.

d) **Propellers:**

Here we are using two propellers one is for take-off and another is for floating purpose

III. SOFTWARE DISCRIPTION:

We are using following software:

a) **PROTEUS:**

We are using Proteus for designing circuits and simulation of those circuits. We are using Proteus 8.0 professional.

b) **EAGLE:**

We are using eagle for making layouts of the circuits. The Eagle 7.6 is used for making layouts of the circuits.

c) **KEIL:**

Kiel is used to test and debugging of the program code used in our project and generation of hex file is done using Keil. We are using Kiel micro Vision 4.



IV. CONCLUSION:

► As we discussed our project is only a model represents a smart village consisting some electronic projects from those we have implemented some parts successfully like smart vehicle, water level indicator, electric water pump using dc motor and remaining parts we will be implementing in few days.

REFERENCES:

- [1] Richard Harkins, Jason Ward and Ravi Vaidyanathan-(July 2005)“Design of an Autonomous Amphibious Robot for surf zone operations: Part II- Hardware , control Implementation and Simulation.”
- [2] Cambridge Malaysian Education and Development Trust (CMEDT)(August 2015)-“Smart villages for off-grid communities worldwide”.
- [3] Mou Riiny-“The smart village initiative”.
- [4] Wallace, David N – “Line Following Robot”.

