



A New Approach to Control of an Induction Motor Drive by Using ANN

¹G. Tirupati Naidu, ²K. V. R. Swathi

¹PG STUDENT, ²Assistant Professor
ANITS, VISAKHAPATNAM,

Email: ¹gtneee@gmail.com, ²swathi.korukonda22@gmail.com

Abstract-Three-level neutral-point-clamped (NPC) inverters are very appropriate for high-power adjustable-speed drive applications. Direct torque control is characterized by the merits of fast response, simple structure and strong robustness to motor parameters variations. This paper presents a 3-level inverter-fed direct torque controlled (DTC) induction motor (IM) drive based on optimized switching table. The problems of high voltage jump, smooth vector switching and neutral point balance are investigated and solved by introducing appropriate intermediate vectors. Induction machine drive based on Direct Torque Control (DTC) allows high dynamic performance with very simple hysteresis control scheme. Conventional Direct Torque Control (CDTC) suffers from some drawbacks such as high current ripple, flux ripple and torque ripple, difficulties in torque as well as flux control at very low speed. In this paper an intelligent approach of artificial neural network to improve the direct torque control of induction machine. Comparison study is carried out between direct torque neural networks control (ANN-DTC) and (CDTC). Both simulation and experimental results are presented to verify the effectiveness of the proposed schemes introduced in this paper.

Keywords: AC motor drives ,speed sensorless, three-level inverter, CDTC, ANN-DTC, Space vector, Torque ripple.

I. INTRODUCTION

Three-level inverters have become widespread in high power industrial applications since they were first proposed by Nabae in 1981 [1]. Compared to 2-level inverters, they have better performance in terms of lower voltage stress across the semiconductors, less harmonic content and lower switching frequency [2]. Direct torque control (DTC) is a kind of high performance control strategy characterized by fast torque response, simple structure (without complicated rotary transformation) and strong robustness against motor parameter variation. Three-level inverter-fed DTC motor drives are very attractive in high power applications because they combine the merits of both 3-level inverters and DTC.

Most papers [3-4] related to DTC concentrate on 2-level inverters; there are few papers related to 3-level DTC [5]. To make 3-level DTC practicable, an appropriate vector should be selected to maintain the neutral point voltage balance and avoid high voltage jump. The principles of a commercial 3-level DTC adjustable speed drive (ASD), as manufactured by ABB, was introduced in [6]; however, there were undesirable high voltage jumps in the line voltage. To reduce the oscillation in the flux and torque, a LC filter was employed which increases the complexity of flux observation. Ref[5] improves the low speed performance of the 3-level DTC by applying the correct intermediate voltage; however, the problems of voltage jump and neutral point balance were not addressed. This paper focuses on the problems of voltage jump and neutral point balance by incorporating an optimized switching table. There is usually large starting current in conventional DTC [7] schemes and this paper solves this problem by introducing the pre-excitation of stator flux. The proposed schemes are simulated and experimentally verified.

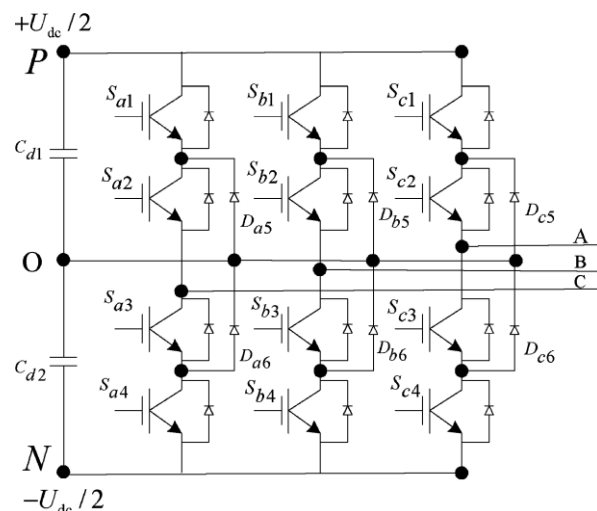

Fig. 1. Main circuit of three-level inverter.

II. DTC FOR 3-LEVEL INVERTER

A. Basic Principle of DTC

The mathematical model of an induction motor described by space vectors in a stationary frame by the following set of equations:

$$U_s = R_s i_s + p \psi_s \quad 2.1$$

$$0 = R_r i_r + p \psi_r - j \omega_r \psi_r \quad 2.2$$

$$\psi_s = L_s i_s + L_m i_r \quad 2.3$$

$$\psi_r = L_m i_s + L_r i_r \quad 2.4$$

where u_s , i_s , i_r , ψ_s and ψ_r are the stator voltage vector, stator current vector, rotor current vector, stator flux linkage vector and rotor flux linkage vector, respectively; R_s , R_r , L_s , L_r , L_m and N_p are the stator resistance, rotor resistance, stator inductance, rotor inductance, mutual inductance and motor pole-pair number; ω_r is the rotor speed.

From the stator voltage equation (1), it can be seen that, by omitting the stator resistance voltage drop, the stator flux can be controlled directly from the stator voltage. This is a crude analysis and may cause error at low speed.

The electromagnetic torque can be expressed as

$$T_e = \frac{3}{2} N_p \frac{L_m}{\sigma L_s L_r} \psi_r^* \psi_s$$

$$T_e = \frac{3}{2} N_p \frac{L_m}{\sigma L_s L_r} \|\psi_r\| \|\psi_s\| \sin \delta_{sr} \quad 2.5$$

where δ_{sr} is the spatial angle between stator flux and rotor flux and T_e is the electromagnetic torque. In the DTC, the amplitude of the stator flux is kept constant and a fast torque response is obtained by changing angle δ_{sr} quickly. From (1)-(4), the relationship between the stator flux and the rotor flux can be obtained from

$$P \psi_r + \left(\frac{1}{\sigma T_r} - j W_r \right) \psi_r = \frac{L_m}{\sigma L_s T_r} \psi_s \quad 2.6$$

where $\sigma = 1 - L_m^2 / (L_s L_r)$ and $T_r = L_r / R_r$. Equation (2.6) indicates that the dynamic response of the rotor flux is a first-order lag with respect to the stator flux, so the torque can be changed quickly by changing the angle of stator flux.

B. Vector Selection and Switching

1) DTC Method I

For a 2-level DTC, the sector division and vector selection methods are relatively mature. However, for a 3-level DTC, because of the increased number of vectors, vector selection is more complicated, and in this paper we will solve the problem step by step.

Firstly, the vector is selected according to the demand of flux and torque; vector switching and neutral point balance will be considered later. Fig. 1 shows the space vector diagram for a 3-level DTC control strategy and its sector division. There are 12 sectors and the shadowed area is the first vector, which is different from that of the conventional 2-level DTC. The basic principles of the vector selection are shown in Table I and these meet the demands of the flux and torque; k represents the stator flux located in k th sector. In addition, “ \uparrow ” means increase while “ \downarrow ” means decrease, and “ $=$ ” means no change is needed. It should be noted that more than two vectors may exist to meet the demands of the flux, and a vector which meets the torque response better is preferred.

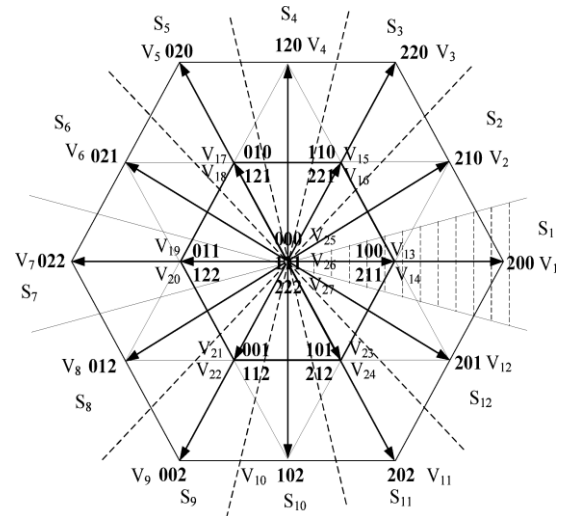

Fig. 1. Space vector diagram for the three-level dtc.

However, in most cases, the selected vector usually cannot meet the requirements of the vector switching and neutral point balance, which means the selected vector cannot be applied to the 3-level inverter directly. For example, suppose the stator flux is located in the first sector, and the current vector is V1 (200). To increase the stator flux and torque, according to Table I, V3 (220) would be the appropriate vector. But there is a high voltage jump in phase B from 0 to 2, which should be avoided. In this case, V2 (210) will be inserted as an intermediate vector to smooth the high voltage jump. There are three aspects to voltage jumps: 1) phase voltage

jump, 2) line voltage jump, 3) 3-phase jump at the same time. High voltage jump increases harmonic content and the stress across power semiconductors, which negates the advantages of the 3-level inverter. To overcome this problem, an appropriate intermediate vector should be inserted to meet the requirement of the voltage jump.

TABLE 1

VECTOR SELECTION TABLE FOR THREE-LEVEL DTC

Flux	Torque	Selected vector number
↑	↑	k+2
	=	26
↓	↓	k-2
	↑	k+4
↓	=	26
	↓	k-4
↑	↑	k+3
	=	26
	↓	k-3

Another issue is the problem of neutral point balance, which is very important for a 3-level inverter, because neutral point unbalance will cause higher voltage in the power semiconductors. This increases the demand of capacity so that the cost increases. Many papers have investigated this problem. Neutral point balance is mainly controlled by selecting appropriate small vectors; this is because of the opposite effects of redundant vectors. In this paper, we also adopt the redundant states of small vector to keep neutral point balance.

The final vector selection rules are obtained by considering the aspects introduced above, and the principles are summarized as follows:

Step I: select vector according to the demands for flux and torque, which are listed in Table I;

Step II: if the selected vector cannot meet the requirement of voltage jump and neutral point balance, an appropriate intermediate vector will inserted, and principles for selecting the intermediate vector are:

- Large vectors or middle vectors should be selected preferably to increase the utilization ratio of DC bus;
- Middle vectors can switch to adjacent small vectors and large vectors freely;
- Large vectors can switch to the small vectors in the same spatial orientation;
- Small vectors can switch to zero vectors freely;

- When small vectors are available, select the one which can meet the requirement of neutral point balance.

Using to the steps above, an appropriate vector can be selected to meet the demand of flux and torque, as well as the requirement of voltage jump and neutral point balance, which ensures the safe operation of the 3-level inverter.

2) DTC Method - II

In DTC method -I, by inserting the appropriate intermediate vector, the problems of neutral point balance and smooth vector switching were solved. However, it may degrade the performance of torque and increase the complexity of vector selection, so another scheme is proposed here.

Method - II makes use of synthesizing vectors, which is termed discrete space vector modulation (SVPWM). This was first proposed in two-level DTC. The two-level SVPWM-DTC incorporates a more complicated and accurate switching table by dividing one sampling period into two or three intervals, and thus, more vectors are obtained.

Speed is also taken into account and more levels of hysteresis are adopted to make the switching table more accurate. The benefits of SVPWM-DTC are reduced torque and flux ripple at a little extra expense of computational time.

This paper extends SVPWM to three-level DTC by using synthesizing vectors and the main aim of introducing SVPWM is to solve the problems of neutral point balance and smooth vector switching. To reduce the complexity of the algorithm, the same structure as Table 1 is adopted and the speed was not taken into account in the switching table. First, we should synthesize some vectors, which are expected to solve the problems of neutral point balance and smooth switching between any two vectors simultaneously.

This means that the vector selection, according to the need of the torque and flux, is decoupled from the circuit limitation introduced by the three-level topology. A series of novel synthesizing vectors are produced, which are illustrated in Fig. 2 and marked by $V_{s1}, V_{s2}, \dots, V_{s12}$.

Take V_{s1} , for example, it is synthesized by the nearest three vectors, namely, $V_1(200)$, $V_2(210)$, and $V_{13}/V_{14}(100/211)$. The duration time of each vector can be calculated easily by utilizing the principle of volt-second balance. To smooth the vector switching, zero vector $V_{26}(111)$ is incorporated at the beginning and ending of

each synthesize sequence, taking up 10% or less duty of the whole period.

The 12 synthesizing vectors are distributed uniformly in the fixed-angle space (15° for V_{s1}) with constant or variable amplitude.

In this paper, constant amplitude for the synthesis vector is selected for simplicity, so the duration of each vector in $V_{s1}, V_{s2}, \dots, V_{s12}$ can be obtained offline and stored in a look-up table for real time implementation. The final synthesizing vectors are listed in Table 3.2 and the sector division for three-level DTC is presented in Fig. 3.2, which has a 15° shift compared to that in Fig. 3.1. From Table 3.1, it is seen that the switching between any arbitrary two vectors or adjacent vectors in a synthesis sequence are smooth. The neutral point balance can be solved by adjusting the “lasting time” of the small vectors in one sampling period. Taking V_{s1} as an example, 211 and 100 are a pair of small vectors and their total “lasting time” is fixed during one sampling period, but their individual working time can be arranged according to the requirement of neutral point balance.

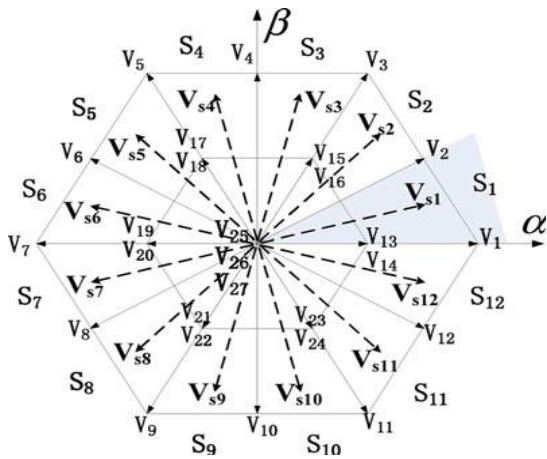

Fig. 2 Synthesis vector diagram.

TABLE 2 -NOVEL VECTOR SYNTHESIS

Vector no.	Vector synthesis sequence
V_{s1}	111-211-210-200-100-200-210-211-111
V_{s2}	111-110-210-220-221-220-210-110-111
V_{s3}	111-110-120-220-221-220-120-110-111
V_{s4}	111-121-120-020-010-020-120-121-111
V_{s5}	111-121-021-020-010-020-021-121-111
V_{s6}	111-011-021-022-122-022-021-011-111
V_{s7}	111-011-012-022-122-022-012-011-111
V_{s8}	111-112-012-002-001-002-012-112-111
V_{s9}	111-112-102-002-001-002-102-112-111
V_{s10}	111-101-102-202-212-202-102-101-111
V_{s11}	111-101-201-202-212-202-201-101-111
V_{s12}	111-211-201-200-100-200-201-211-111

DTC method-II employs the same switching table, as shown in Table 1, except that the selected vector is replaced by the novel synthesis vector listed in Table 2. For example, if the selected vector number is k according to Table 1, the synthesized vector V_{sk} will be selected as the output vector, and number 26 means the zero vector 111.

For DTC method - I, a further step- II should be taken before the final vector is selected; however, this process is not needed in method-II, which simplifies the selection of vector. An example of switching pattern for the two kinds of DTC method is illustrated in Fig. 3. It is seen that for DTC method- I, there is only one vector in one sampling period, while there is a sequence of vectors for DTC method - II, with 111 as the beginning and ending.

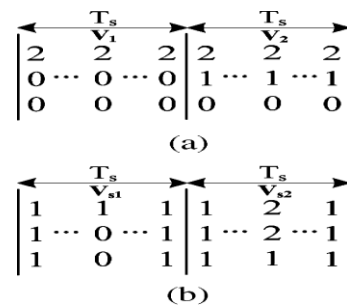

Fig. 3 Example of switching pattern. (a) DTC method I. (b) DTC method II.

C. Decreasing Starting Current

To decrease starting current and maintain sufficient starting torque, the scheme of pre-excitation of stator flux is proposed in this paper. The stator flux will firstly be established by applying an appropriate vector, and during the pre-excitation process, the starting current is sampled and when it reaches the limit, zero vectors will be selected to decrease the current, which acts in a bang-bang fashion. When stator flux enters the range of demand, the process of pre-excitation is terminated and motor can start with sufficient torque, because there is enough flux to produce torque.

III PRINCIPLE OF ARTIFICIAL NEURAL NETWORK

Artificial neural networks use a dense interconnection of computing nodes to approximate nonlinear functions [15][16]. Each node constitutes a neuron and performs the multiplication of its input signals by constant weights, sums up the results and maps the sum to a nonlinear activation function g; the result is then transferred to its output. A feed forward ANN is organized in layers: an input layer, one or more hidden layers and an output layer.

Where the Layer1 and Layer2 given by Fig..8.

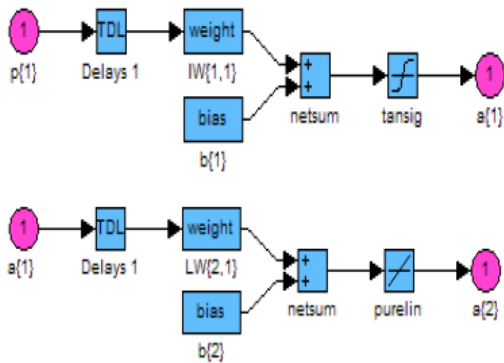

Fig. 8 Block Layer1 and Layer2

IV. SIMULATION AND EXPERIMENTAL RESULTS

To validate the effectiveness of the proposed techniques introduced in this paper, a system is simulated then validated experimentally, and the results are presented here. Fig. 5 illustrates the arrangement of the sensorless 3-level DTC drive based on ANN is implemented. The parameters for the simulation are listed.

V. SIMULATION AND EXPERIMENTAL PARAMETERS

The parameters for 1.5 hp, 4-pole, and 50Hz induction motor are given below

- Supply voltage =310 Volts
- Stator circuit resistance = 7.83 ohms
- Rotor circuit resistance = 7.55 ohms
- Inductance of stator circuit = 0.4751H
- Inductance of rotor circuit = 0.4751H
- Mutual inductance = 0.4535H
- Moment of inertia = 0.013 Kg.m²
- Load torque =25Nm

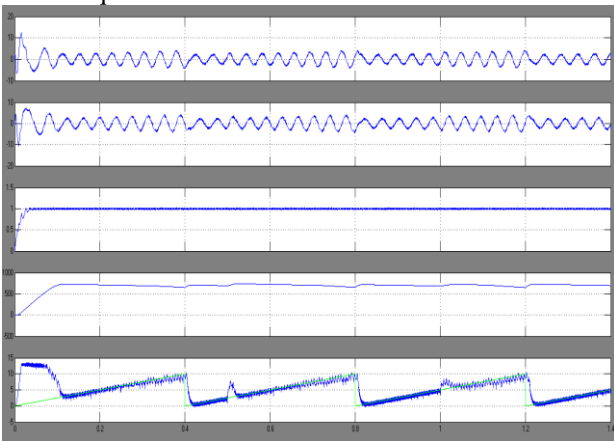

Fis.8 Simulation Results for id,iq,flux,speed,torque with PI controller

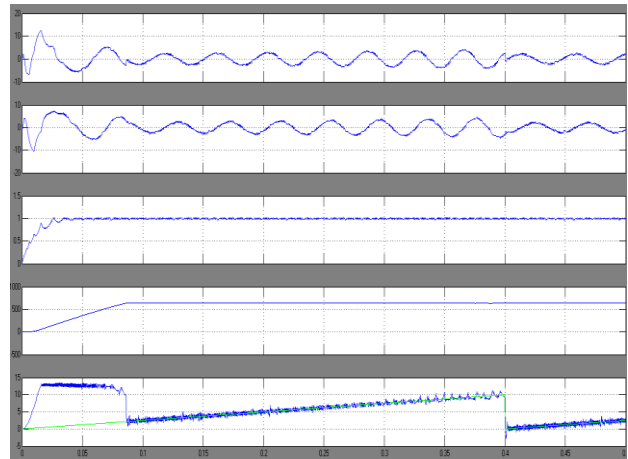

Fis.9 Simulation Results for id,iq,flux,speed,torque with ANN controller

VI. CONCLUSION:

A 3-level inverter-fed induction motor drive is presented in this paper, which incorporates an optimal vector table . Some aspects, including voltage jump, neutral point balance and large starting current, are investigated to assess the practicality of the 3-level DTC. The principles of the vector selection procedures are established and the pre-excitation technique is proposed to decrease the starting current. In this paper a ANNDTC of induction machine have been proposed. An improved torque response in terms of decreased torque ripple was achieved with the ANNDTC than the CDTC. The performance has been tested by simulations. The main improvements shown are reduction of torque ripples in transient and steady state response.

REFERENCES

- [1] A.Nabae, I. Takahashi, and H.Akag, "A new neutral-point clamped PWM inverter," IEEE Trans. Ind. Applicat., vol. 17, no. 5, 1981, pp. 518-523.
- [2] J. Rodriguez, J. Sh. Lai, and F. Zh. Peng, "Multilevel inverters: a survey of topologies, controls, and applications," IEEE Trans. Ind. Electron., vol. 49, no. 4, 2002, pp. 724-738.
- [3] Casadei D, Profiuno F, Serra G, et al. FOC and DTC: two viable schemes for induction motors torque control. IEEE Trans. Power Electron., vol. 17, no. 5, 2002, pp. 779-787.
- [4] Giusepp S. Buja, Marian P. Kazmierkowski. Direct torque control of PWM inverter-fed AC

- motors-a survey. IEEE Trans. Ind. Electron., vol. 51, no. 4, 2004, p744-757
- [5] L. Kyo-Beum, S. Joong-Ho, I. Choy, et al. Improvement of low-speed operation performance of DTC for three-level inverter-fed induction motors. IEEE Trans. Ind. Electron., vol. 48, no. 5, 2001, pp. 1006-1014
- [6] Sapin A., Steimer P.K., Simond J.J. Modeling, Simulation, and Test of a Three-Level Voltage-Source Inverter with Output LC Filter and Direct Torque Control. IEEE Trans. Ind. Electron., vol. 43, no. 2, 2007, pp. 469-475.
- [7] Juhasz G, Halasz S, Veszpremi K. New aspects of a direct Torque controlled induction motor drive. IEEE ICIT'00, 2000, no.1, pp. 43-48.
- [8] Yongchang Zhang, Zhengming Zhao. "Speed Sensorless Control for Three-Level Inverter-Fed Induction Motors Using an Extended Luenberger Observer," in proc. IEEE Vehicle Power and Propulsion Conference, Harbin, Sept. 2008, CD-ROM..
- [9]. Takahashi, T. Noguchi, "A new quick response and high- Efficiency control strategy of induction motor", IEEE Trans. On IA, Vol.22, N°.5,Sept/Oct 1986, PP.820-827.
- [10] M. Depenbrock, "Direct self – control (DSC)of inverter fed induction machine", IEEE Trans. Power Electronics, vol.3, No.4, Oct 1988,PP.420-829.
- [11]. Luis A. Cabrera, Malik E. Elbuluk and Iqbal Husain, "Tuning the Stator Resistance of Induction Motors Using Artificial Neural Network" IEEE Transactions On Power Electronics, Vol. 12, No. 5, September 1997.
- [12] Miroslaw Was, Zbigniew Krzeminski, Jaroslaw Guzin'ski, Haithem Abu-Rub and Hamid A. Toliyat, "Artificial-Neural- Network-Based Sensorless Nonlinear Control of Induction Motors" IEEE Transactions On Energy Conversion, Vol.20, No. 3, September 2005
- [13] G, Cirrincione, M, Chuan Lu and Pucci, M "Direct Torque Control of Induction Motors By Use of The GMR Neural Network" Neural Networks, 2003. Proceedings of the International Joint Conference on Volume 3, Issue , 20-24 July 2003 Page(s): 2106 – 2111 vol.3
- [14]. Xuezhi Wu and Lipei Huang, "Direct Torque Control of Three-Level Inverter Using Neural Networks as Switching Vector Selector" Industry Applications Conference, 2001. Thirty-Sixth IAS Annual Meeting. Conference Record of the 2001 IEEE Volume 2, Issue , 30 Sep-4 Oct 2001 Page(s):939 - 944 vol.2
- [15]. Ghouili, J and Cheriti, A" Induction motor dynamic neural stator flux estimation using active and reactive power for direct torque control ."Power Electronics Specialists Conference, 1999. PESC 99. 30th Annual IEEE Volume 1, Issue , Aug 1999 Page(s):501 - 505 vol.
- [16]. A. Ba-razzouk, A. Cheriti and G. Olivier, "A Neural Networks Based Field Oriented Control Scheme For Induction Motor "IEEE Industry Applications Society Annual Meeting New Orleans, Louisiana, October 5-9, 1997
- [17]. Chengzhi Cao, Mu-Ping Lu and Xin Wang, "Speed Estimation And Stimulation Of Dtc System Based On Wavelet Neural Network "Proceedings of the Second International Conference on Machine Learning and Cybernetics, Xi", 2-5 November 2003
- [18]. Xianmin Ma and Zhi Na "Neural network speed identification scheme for speed sensor-less DTC induction motor drive system "Power Electronics and Motion Control Conference, 2000. Proceedings. IPEMC2000. The Third International Volume 3, Issue , 2000 Page(s):1242 –1245 vol.3.

