



IOT Based Secure System For Monitoring And Control of Coal Mine Environment of Robotics.

¹K.Jhansi Rani, ²K.Niranjan Reddy

¹PG Student (M.Tech ES), Dept. of ECE, Mallareddy Engineering College for women, JNTU Hyderabad, India

²Assistant Professor, Dept. of ECE, Mallareddy Engineering College for women, JNTU Hyderabad, India

Abstract: In previous robots, the navigation of robot is controlled through GSM or either through Bluetooth/XBEE. Robots were navigated through a simple SMS, but you can't see visually what's there in front of the robot. The status of sensor is feed backed to the system through a SMS. In the same way with Bluetooth / XBEE. In the proposed solution, a simple USB Web Cam is interfaced to the processor for live streaming to see what's happening in front of the robot and the navigation is controlled through Internet. Have to alert the people in Emergency

I. INTRODUCTION

A coal mine enterprise is a high risk profession and technique. In recent years, the situation about which safety production is serious in the coal mine field, hazard accidents are occurring. So they cause huge losses for the miner's and property losses. It has been observed that most of the accidents occur mainly due to lack of systematic monitoring and maintenance operations. To minimize the chance of accidents and thereby increasing the productivity of the mining operations using autonomous robots. Every mining operation needs a special attention in order to deflate the chances of any kind of accidents. It has been initiated to carry out this task without human intervention using the field of robotics.



Fig: Hardware section of Robot

II. EXISTING SOLUTION:

In previous robots, the navigation of robot is controlled through GSM or either through Bluetooth/XBEE. Robots were navigated through a simple SMS, but you can't see visually what's there in front of the robot. The status of sensor is feed backed to the system through a SMS. In the same way with Bluetooth / XBEE.

III. PROPOSED SOLUTION:

In the proposed solution, a simple USB Web Cam is interfaced to the processor for live streaming to see what's happening in front of the robot and the navigation is controlled through Internet. Have to alert the people in Emergency.

IV. IMPLEMENTATION:

Raspberry Pi, an ARM11 based processor with 512MB of RAM and 8GB of SD Card is used as a main processor of this project. USB Web Camera, USB Wi-Fi Dongle are connected to the Raspberry Pi at the USB ports for live streaming and to connect Internet. A web server is hosted in Raspberry Pi for live streaming (MOTION), and another web server is also hosted in Raspberry Pi for controlling the robot (FLASK). Both were created upon a boot, and a client smartphone is connected to the server for controlling the robot. Camera will be on automatically upon a boot and it captures the frames and upload them to the server. A simple robot bridge is created using Flask for navigating the robot in every possible direction. Gas Sensor is also interfaced to Raspberry Pi to check the existence of harmful gases. Web page will be refreshed for every 3 seconds to display the status of the sensor.

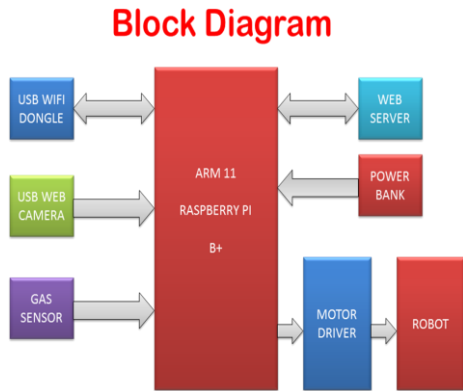

Fig: Block Diagram of Embedded Lower Computer Terminal.

V. HARDWARE USED:

A. Raspberry Pi B+

The Below is Raspberry Pi model B will help you to find out what peripherals present on Raspberry pi board. With help of this we are going to start the Raspberry Pi.

Before going to start it first find out what we want to connect to Raspberry Pi and what we need to boot the OS into Raspberry Pi.

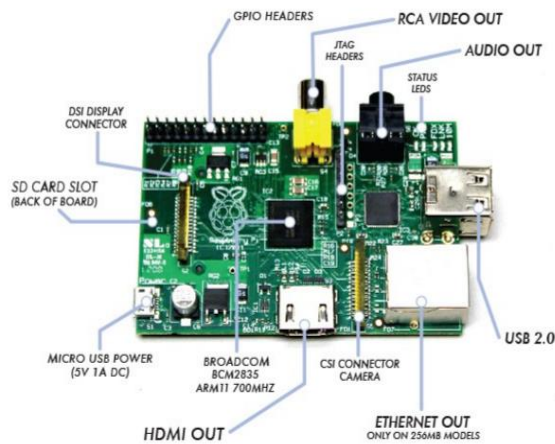

Fig: Raspberry Pi

Requirements:

- HDMI Cable (For display purpose, it can be connected to LCD display or desktop)
- Micro USB power (it contains 5V,1A DC)
- SD Card and followed by its adapter for Operating System
- For Input devices like KEYBOARD and MICE is connected to the USB Ports
- Ethernet Cable (for option you can connect WIFI Modem instead of Ethernet cable)

INSTALLING OS INTO SD CARD:

For installing here I used two software's and one operating system called Wheezy Raspbian.

1. SDFormatterv4(for format your SD card)
2. Win32DiskImager-0.9.5(to install OS into your SD card)
3. Last Operating System is Wheezy Raspbian newest version (2014-09-09)

First two are must be installed on your PC or Laptop and additional you must download this Operating system on your Laptop and it is open source

The following steps are will show you how to boot the OS

BOOT THE OS:

Step 1:

Insert your SD card into Adapter like below and put it in your laptop.

Note: 4GB of SD card is minimum but I prefer 8GB SD card



Fig: SD Card and Adapter

Step 2:

Open SD formatter and format your SD Card after inserting into your laptop or PC. That will look like below

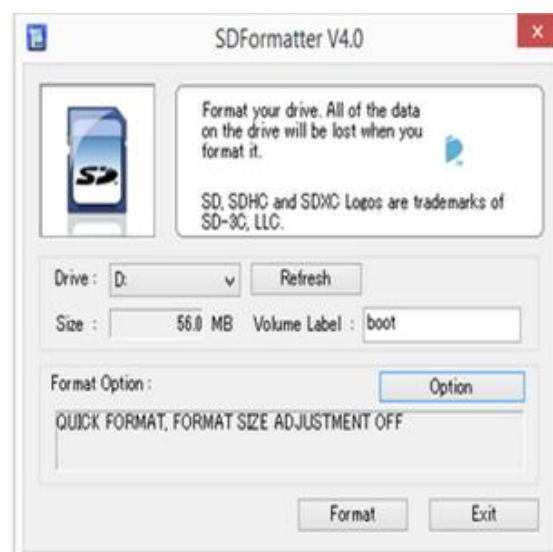

Press Format button over there then it will automatically format.

Step 3:

Next open Win32DiskImager that look like below

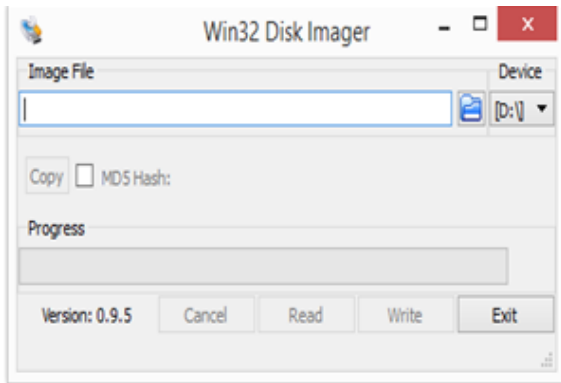

There you will find folder icon click over there then select Wheezy Raspbian that have already downloaded into your laptop.

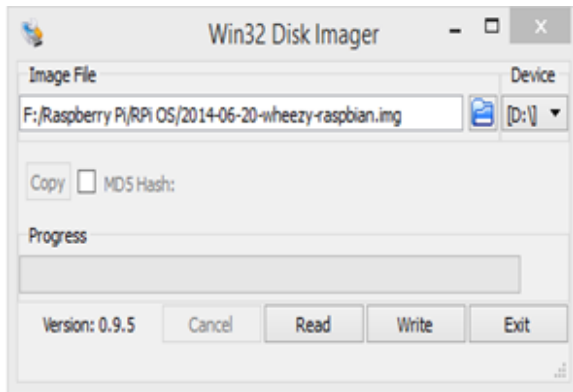

Now click on Write button you can find there. Then it will automatically install into the SD Card. You must wait until it has finished.

Step 4:

After writing OS into the SD Card then take it off from your laptop and put it into the Raspberry pi directly if it is Model B, or if it is Model B+ then just insert your small SD card without adapter. I'm showing you below on Model B



Step 5:

Next connect Keyboard and Mice in USB slots and Ethernet cable and also micro power



After connecting all then you will get Linux shell on your display like below

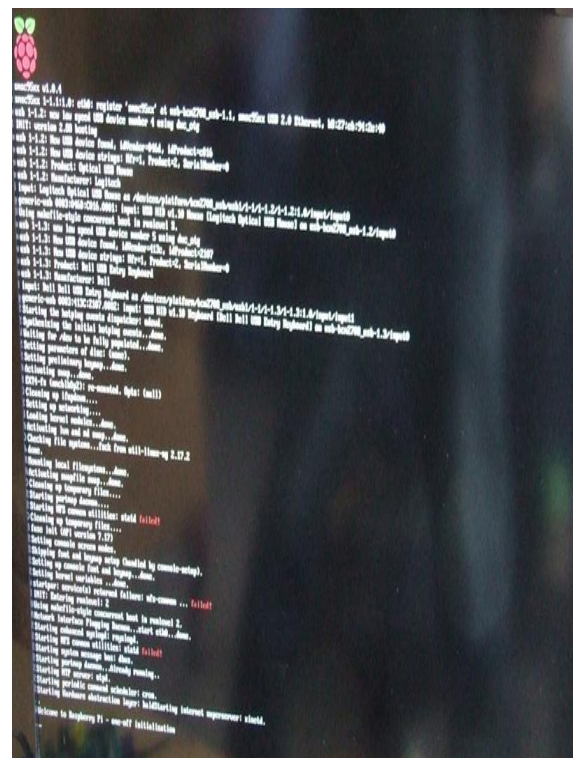

Then you will get pop up window of raspberry pi configuration, you just use up and down arrows on your keyboard and press finish there then you will get entry level there you reboot your system. For reboot type sudo reboot then it is automatically rebooting your system then you will get the window there you need to enter the username and password.

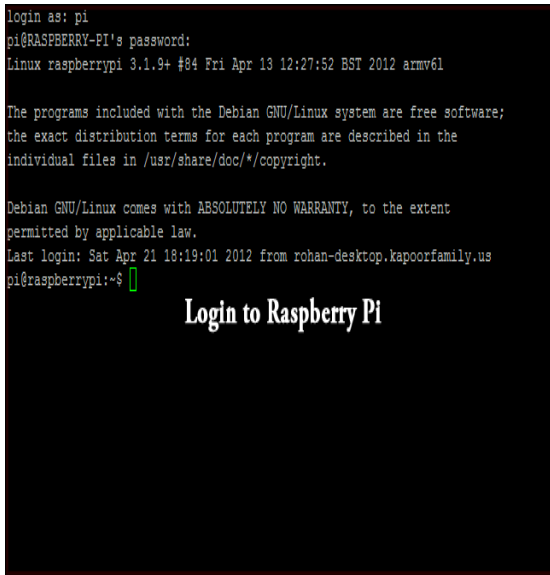

After that enter startx command that will entering you into raspberry pi GUI.

This is how you are booting OS into the Raspberry Pi.

B. Robotics

For this project, we will be using three pairs of IR sensors which will be attached to the bottom of the robot. These 3 sensors will be classified as left sensor, middle sensor and right sensor. A view of the placement of the sensors is as below:

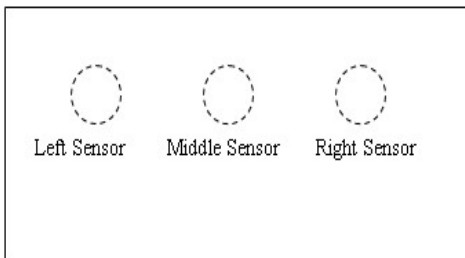

View from the top of the robot

The distance between the two sensors depends on the width. The sensor should be placed in such a way that maximum distance of two sensors is equal to the width of the line as shown in figure below.

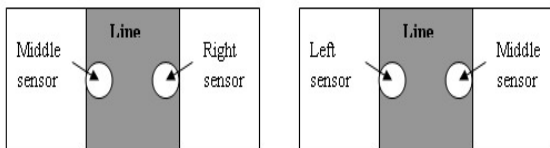

Sensor			Response
Left	Middle	Right	
W	B	W	Go Straight
B	W	W	Turn Left
W	W	B	Turn Right

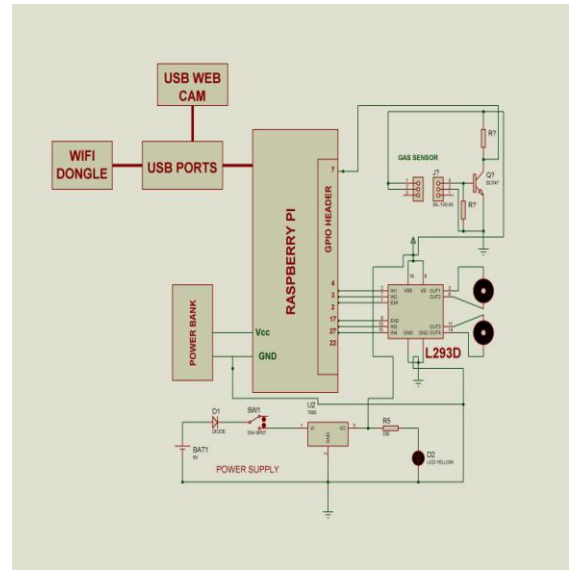
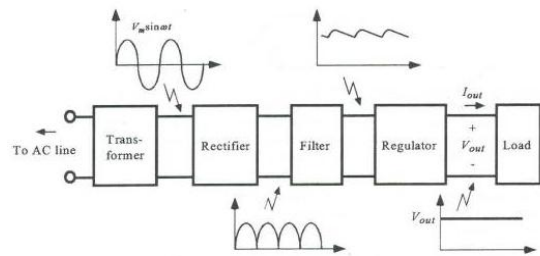

Fig: IOT Controlled Robot

C. Power Supply:

The input to the circuit is applied from the regulated power supply. The a.c. input i.e., 230V from the mains supply is step down by the transformer to 12V and is fed to a rectifier. The output obtained from the rectifier is a pulsating d.c voltage. So in order to get a pure d.c voltage, the output voltage from the rectifier is fed to a filter to remove any a.c components present even after rectification. Now, this voltage is given to a voltage regulator to obtain a pure constant dc voltage.



Components of a regulated power supply

Transformer:

Usually, DC voltages are required to operate various electronic equipment and these voltages are 5V, 9V or 12V. But these voltages cannot be obtained directly. Thus the a.c input available at the mains supply i.e., 230V is to be brought down to the required voltage level. This is done by a transformer. Thus, a step down transformer is employed to decrease the voltage to a required level.

Rectifier:

The output from the transformer is fed to the rectifier. It converts A.C. into pulsating D.C. The rectifier may be a half wave or a full wave rectifier. In this project, a bridge rectifier is used because of its merits like good stability and full wave rectification.

Filter:

Capacitive filter is used in this project. It removes the ripples from the output of rectifier and smoothens the D.C. Output received from this filter is constant until the mains voltage and load is maintained constant. However, if either of the two is varied, D.C. voltage received at this point changes. Therefore a regulator is applied at the output stage.

Voltage regulator:

As the name itself implies, it regulates the input applied to it. A voltage regulator is an electrical regulator designed to automatically maintain a constant voltage level. In this project, power supply of 5V and 12V are required. In order to obtain these voltage levels, 7805 and 7812 voltage regulators are to be used. The first number 78 represents positive supply and the numbers 05, 12 represent the required output voltage levels.

D. Driver circuit for motor:

Digital systems and microcontroller pins lack sufficient current to drive the circuits like relays, buzzer circuits, motors etc. While these circuits require around 10milli amps to be operated, the microcontroller’s pin can provide a maximum of 1-2milli amps current. For this reason, a driver such as a power transistor is placed in between the microcontroller and the motor.

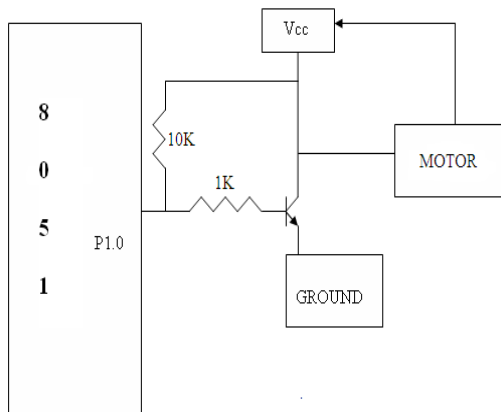

The operation of this circuit is as follows:

The input to the base of the transistor is applied from the microcontroller port pin P1.0. The transistor will be switched on when the base to emitter voltage is greater than 0.7V (cut-in voltage). Thus when the voltage applied to the pin P1.0 is high i.e., P1.0=1 (>0.7V), the transistor will be switched on and thus the motor will be ON.

When the voltage at the pin P1.0 is low i.e., P1.0=0 (<0.7V) the transistor will be in off state and the motor will be OFF. Thus the transistor acts like a current driver to operate the motor accordingly.

Motor interfacing with the Microcontroller:

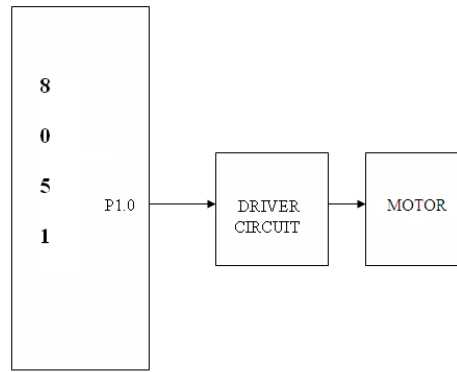

E. MQ-2 Semiconductor Sensor for Combustible Gas

Sensitive material of MQ-2 gas sensor is SnO₂, which with lower conductivity in clean air. When the target combustible gas exist, The sensor’s conductivity is more higher along with the gas concentration rising. Please use simple electrocircuit, Convert change of conductivity to correspond output signal of gas concentration. MQ-2 gas sensor has high sensitivity to LPG, Propane and Hydrogen, also could be used to Methane and other combustible steam, it is with low cost and suitable for different application.

Character

- Good sensitivity to Combustible gas in wide range
- High sensitivity to LPG, Propane and Hydrogen
- Long life and low cost
- Simple drive circuit

Application

- Domestic gas leakage detector
- Industrial Combustible gas detector
- Portable gas detector

Configuration

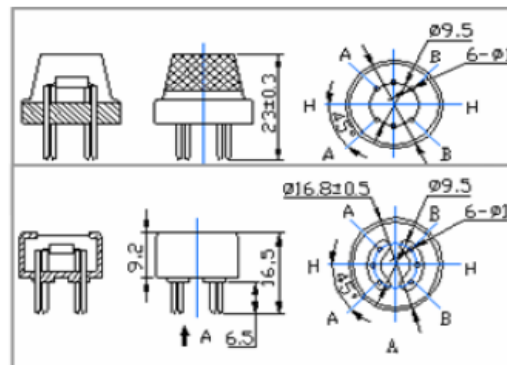

Fig: Configuration.

Technical Data

Model No.		MQ-2	
Sensor Type		Semiconductor	
Standard Encapsulation		Bakelite (Black Bakelite)	
Detection Gas		Combustible gas and smoke	
Concentration		300-10000ppm (Combustible gas)	
Circuit	Loop Voltage	V_c	$\leq 24V$ DC
	Heater Voltage	V_H	$5.0V \pm 0.2V$ AC or DC
	Load Resistance	R_L	Adjustable
Character	Heater Resistance	R_H	$31\Omega \pm 3\Omega$ (Room Tem.)
	Heater consumption	P_H	$\leq 900mW$
	Sensing Resistance	R_s	$2K\Omega - 20K\Omega$ (in 2000ppm C_2H_6)
	Sensitivity	S	$R_s(\text{in air})/R_s(1000\text{ppm isobutane}) \geq 5$
	Slope	α	$\leq 0.6 (R_{5000\text{ppm}}/R_{3000\text{ppm}} CH_4)$
	Condition	Tem. Humidity	$20^\circ C \pm 2^\circ C$; $65\% \pm 5\% RH$
Condition	Standard test circuit	$V_c: 5.0V \pm 0.1V$; $V_H: 5.0V \pm 0.1V$	
	Preheat time	Over 48 hours	

Basic test loop

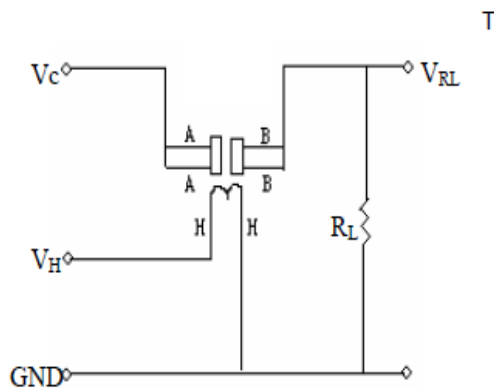

Fig: Basic Test Loop

The above is basic test circuit of the sensor. The sensor need to be put 2 voltage, heater voltage V_H and test voltage V_C . V_H used to supply certified working temperature to the sensor, while V_C used to detect voltage (V_{RL}) on load resistance (R_L) whom is in series with sensor. The sensor has light polarity, V_c need DC power. V_C and V_H could use same power circuit with precondition to assure performance of sensor. In order to make the sensor with better performance, suitable R_L value is needed: Power of Sensitivity body(P_s): $P_s = V_c^2 \times R_s / (R_s + R_L)^2$

Sensitivity Characteristics

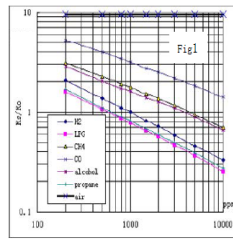

Fig.1 shows the typical sensitivity characteristics of the MQ-2, ordinate means resistance ratio of the sensor (R_2/R_0), abscissa is concentration of gases. R_s means resistance in different gases, R_0 means resistance of sensor in 1000ppm Hydrogen. All test are under standard test conditions.

Influence of Temperature/Humidity

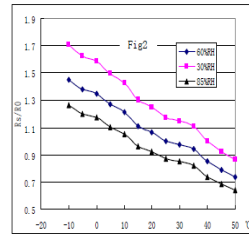

Fig.2 shows the typical temperature and humidity characteristics. Ordinate means resistance ratio of the sensor (R_s/R_0), R_s means resistance of sensor in 1000ppm Butane under different tem. and humidity. R_0 means resistance of the sensor in environment of 1000ppm Methane, $20^\circ C/65\% RH$

Structure and configuration

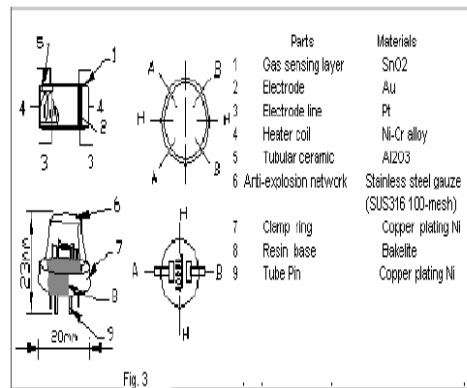

Fig: Structure and configuration of MQ-2 gas sensor

Structure and configuration of MQ-2 gas sensor is shown as Fig. 3, sensor composed by micro AL_2O_3 ceramic tube, Tin Dioxide (SnO_2) sensitive layer, measuring electrode and heater are fixed into a crust made by plastic and stainless steel net. The heater provides necessary work conditions for work of sensitive components. The enveloped MQ-2 have 6 pin, 4 of them are used to fetch signals, and other 2 are used for providing heating current

VI. APPLICATIONS:

- Internet of Things Controlled Home Automation.
- IOT Based Data Logger
- IOT Based Entertainment Environment
- IOT Based Agricultural Devices Control

VII. RESULT :

In this project IOT based secure system for monitoring and control of coal mine environment of robotics based on Raspberry Pi using sensor MQ5 was proposed implemented and deployed that successfully detected accidents in coal mains.

VIII. CONCLUSION:

The project "IOT BASED SECURE SYSTEM FOR MONITORING AND CONTROL OF COAL MINE ENVIRONMENT OF ROBOTICS" has been successfully designed and tested. It has been developed

by integrating features of all the hardware components and software used. Presence of every module has been reasoned out and placed carefully thus contributing to the best working of the unit. Secondly, using Raspberry pi and with the help of growing technology the project has been successfully implemented.

REFERENCES:

- [1] Z. B. Liu, H. B. Xin, and W. J. Wang, "Status of Study on Internet Robotics and its Control System, "Journal of Beijing Technology and Business University(Natural Science Edition), vol. 24, pp. 32-36, March 2006.
- [2] <http://longkeafdz.com/supply/SS046279.html>.
- [3] W. B. Wei, Y. D. Pan, and Katsuhisa Furuta, "Design of Internet-based Telerobot Controller, " Control Engineering of China, vol. 13, pp. 168-171, February 2006.
- [4] N. Wu and P. Y. Guo, "Communications System of Long-Distance Robot Based on E-Link Network Data Transport Technique, "Journal of Beijing Technology and Business University(Natural Science Edition), Vo1. 2S, pp. S2-S4, January 2007.
- [5] <http://www.doc88.com/p-017703120649.html>.
- [6] Q. H. Zhang and Y. Ni, "The design of fire detecting robot communication control system," Fire Science and Technology, "Vo1. 30, pp. 71S-717, August 2011.
- [7] <http://www.safehoo.com/Emergency/Theory/20130S/313222.shtml>.
- [8] J. Q. Li, Q. Zhao, and D. W. Liu, "Design of Mine Rescue robot, " School of Automation, Nanjing Institute of Technology, NanJng, China, June 2011.
- [9] Cai Luo; Espinosa, A.P.; De Gloria, A.; Sgherri, R., "Air-ground multi-agent robot team coordination," Robotics and Automation (ICRA), 2011 IEEE International Conference on Robotics and Automation, vol., no., pp.6588,6591, 9-13 May 2011
- [10] Reddy, S.K.; Krishna, G.B., "HAZARDOUS GAS DETECTING RESCUE ROBOT IN COAL MINES," Internations Journal of Mechanical And Production Engineering, vol. 2, issue 5, May 2014
- [11] Sugiyama, H.; Tsujioka, T.; Murata, M., "Intergrated Operations of Mutli-Robot rescue System with Ad Hoc Networking," Osaka City University, 2008
- [12] Ward. C, Iagnemma. C.K, "A Dynamic Mobile Based Wheel Slip Detector for Mobile Robots on Outdoor Terrain", Robotics, IEEE Transactions on Volume 24, Issue 4, Page(s):821-831, Aug 2008.

