

Design, Analysis and Optimization of Flywheel

¹Pratik Kalaskar, ²Harshal Patil, ³Nikhil Raut, ⁴Amit Narwade

¹Assistant professor, ²Assistant professor, ³Assistant professor

Email: ¹kalaskar.pratik.v@gmail.com, ²harshal2605@gmail.com, ³nikhilr617@gmail.com, ⁴narwadeamit25@gmail.com

Abstract—In this paper we have optimized the weight and cost of flywheel by using different materials and stress analysis using finite element method. Finally we compared with the genetic algorithm to calculate the optimized weight. In optimizing we have considered the different geometries of flywheel. The net torque imparted to the crankshaft during one complete cycle of operation of engine fluctuates causing a change in the angular velocity of shaft. In order to achieve a uniform torque, an inertia mass in the form of a wheel is attached to the out shaft and the wheel is called the flywheel. The finite element model of flywheel is considered and the analysis is done with the help of ANSYS. ANSYS is general purpose software, which can be used for almost any type of finite elements analysis virtually in any industry – automobiles, aerospace, etc. General purpose also refers to the fact that software can be used in all disciplines of engineering-structural, mechanical, electrical, electromagnetic, thermal. The project involves the design and analysis of flywheel to minimize the fluctuation in torque, the flywheel is subjected to a constant rpm. The objective of present work is to design, analysis and optimize the flywheel for the best material. The FEA model is described to achieve a better understanding of the mesh type and boundary conditions applied to complete an effective FEA model. FEA provides the ability to analyze the stresses and displacements of a part or assembly, as well as the reaction forces other elements are to impose. At last the design objective could be simply to minimize cost of flywheel by reducing material.

Index Terms— Flywheel, Finite Element Analysis (FEA) and Design Optimization

I. INTRODUCTION

The concept of a flywheel is as old as the axe grinder's wheel, but could very well hold the key to tomorrow's problems of efficient energy storage. The flywheel has a bright outlook because of the recent achievement of high specific energy densities. A simple example of a flywheel is a solid, flat rotating disk. David Eby, R. C. Averill explained the term shape optimization with the help of genetic algorithm.

A flywheel is an inertial energy-storage device. It absorbs mechanical energy and serves as a reservoir, storing energy during the period when the supply of energy is more than the requirement and releases it during the period when the requirement of energy is more than the supply. The main function of a flywheel is to smoothen out variations in the speed of a shaft caused by torque

fluctuations. If the source of the driving torque or load torque is fluctuating in nature, then a flywheel is usually called for. Many machines have load patterns that cause the torque time function to vary over the cycle. Internal combustion engines with one or two cylinders are a typical example. Piston compressors, punch presses, rock crushers, etc. are the other systems that have fly wheel.

The Finite Element Method is a numerical analysis technique for obtaining approximate solutions to a wide variety of engineering problems. Finite Element Modeling (FEM) and Analysis (FEA) are the two most popular mechanical engineering applications offered by existing CAD/CAM systems. This is attributed to the fact that the finite element method is perhaps most popular numerical technique for solving problems. The method is general enough to handle any complex shape or geometry, any material property, any boundary conditions, and any loading conditions.

The present project deals with flywheel. A flywheel is generally attached to shaft in order to have uniform torque throughout the shaft. They store energy at some time and give up when desired. So flywheel can be considered as energy reservoir, which gives energy at desired time.

- Flywheels as energy storage

Flywheels are generally used for kinetic energy storage and have been around since the early times of man. Every object rotating around an axis stores some amount of kinetic energy and could in theory be called a flywheel. But the word flywheel is usually used for constructions whose main purpose is the storage of kinetic energy through rotation. This has led to the convention that the term flywheel describes a rotating, cylindrical object, usually of considerable mass, whose main purpose is to store energy or to increase the moment of inertia of a given system.

II. GOALS

The following list of goals was set up in order to be able to evaluate the work progress. In no particular order the goals were as follows:

- Investigate the feasibility of materials as the main energy storage of a high speed flywheel.

- If proven feasible, begin the design of flywheel. Design includes general geometry as well as operating loads and manufacturing processes.
- Analysis of flywheel using software like ANSYS under its different forces acting on flywheel.
- Final step is Optimization of flywheel.

III. MODELLING OF FLYWHEEL

Specification

Model- Maruti Suzuki Swift

Maximum power = 76HP @ 4000 rpm = 56.67kW

Present weight of flywheel = 26 Kg

IV. MATERIAL STRENGTH

Stronger materials could undertake large operating stresses, hence could be run at high rotational speeds allowing to store more energy. Hence could be run at high rotational speeds allow wing to store more energy. In this paper, we have used four different material for determining the best material to bear maximum stress and rotational speed. Materials such as Gray Cast Iron, Al Alloy, Cast Alloy, Maraging steel, etc having different strength and density.

V. GEOMETRY

Specific energy storage depends on the mass of flywheel. To improve specific energy stored in flywheel we have to reduce the mass. We can reduce the mass using the different geometry. To improve the quality of the product and in order to have safe and reliable design, it is necessary to investigate the stresses induced in the component during working condition. When the flywheel rotates, centrifugal forces acts on the flywheel due to which tensile and bending stress are induced in a flywheel.

VI. DESIGN OF FLYWHEEL

The flywheel is mounted on the shaft of 31.8mm diameter. The flywheel is rotating with a mean angular velocity of 4000 rpm. The flywheel is analyzed for four materials and compared for the best material among them.

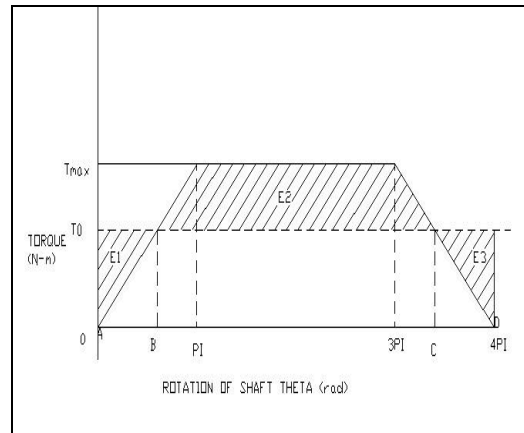

Fig.1 T-θ diagram

T-θ diagram is used for finding

$$T_{max} = 180.386 \text{ N-m,}$$

$$\text{average torque (T}_0\text{)} = 135.289 \text{ N-m,}$$

$$\text{Work done per cycle } W = 1700 \text{ J}$$

$$\text{Fluctuation of energy } (\Delta E) = 318.786 \text{ J}$$

$$\text{Coefficient of fluctuation of energy (C}_e\text{)} = 0.187$$

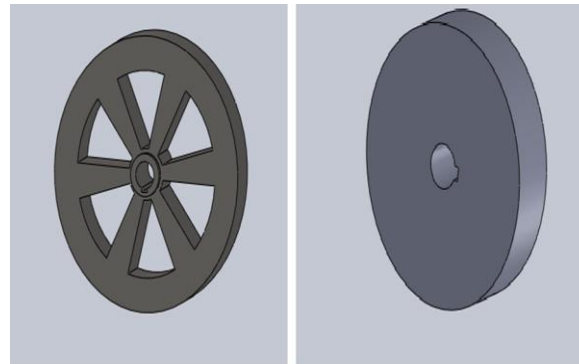

Fig 2 Various profiles of flywheel

VII. FLYWHEEL GEOMETRIES

This study clearly depicts the importance of flywheel geometry design selection and its contribution in the energy storage performance. Although this improvement is to be thought small, it still could be crucial for mission critical operations .other profiles of flywheel given below are designed and analyzed.

Table 1 Comparison of functional values of flywheel.

Functional Values	Moment of inertia I	Kinetic energy stored ΔE	Mass M (Kg)	Specific energy (kJ/Kg)
-------------------	---------------------	----------------------------------	-------------	-------------------------

	(Kg-m2)	(kJ)		
Solid	0.06047	0.318786	11.788	0.027
Rimmed	0.3375	0.1974	16.832	0.1171

VIII. FINITE ELEMENT ANALYSIS USING SOLID-WORK

These four profiles of flywheel used are analyzed by FE software ie. Solid work software. FE analysis is carried out for different cases of loading applied on flywheel and maximum von mises stresses and total deformation are determined.

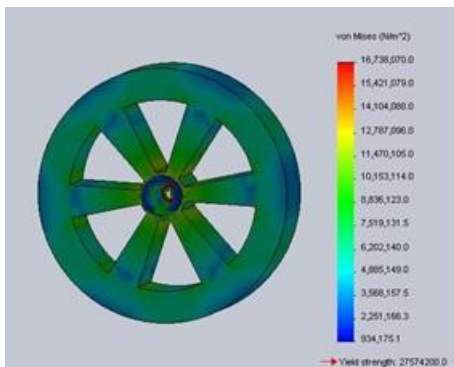

Fig. 3 Von-Misses stress on rimmed flywheel.

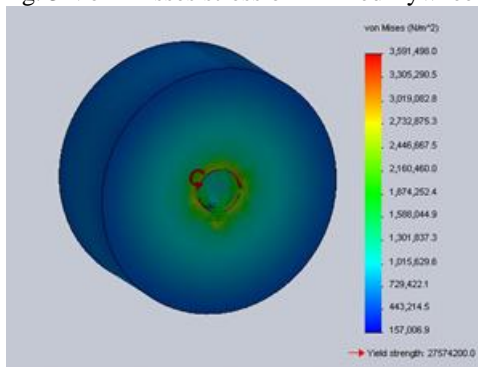

Fig. 4 Von-Misses stress on solid disc flywheel

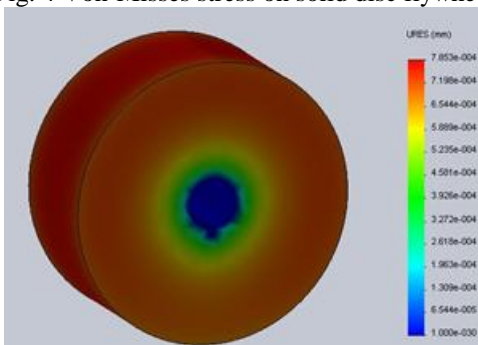

Fig.5 Analysis of Displacement in rimmed flywheel.

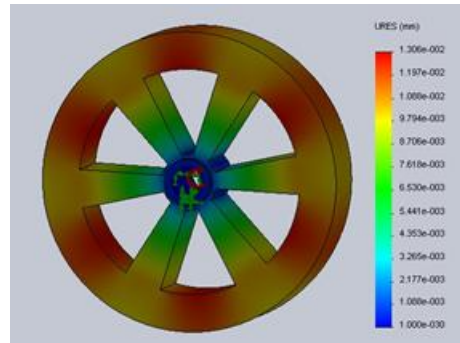

Fig. 6 Analysis of Displacement in solid disc flywheel.

Table 2- Comparison of analysis of flywheel

Type of flywheel	Load (rad/s)	Max. Von-mises stresses (MPa)	Total deformation (mm)
Solid	418.879	3.5915	0.00078
Rimmed	418.879	16.74	0.01305

From this comparison of von-mises stress and deformation of flywheel, we can say that solid disc flywheel having less deformation as well as stresses acting on it by keeping other parameters constant.

IX. OPTIMIZATION OF FLYWHEEL

We can optimize the design of the flywheel by reducing the mass, shape and size as well as the material. Material should be selected such a way that it should bear the all stresses acting on it and that material is of less costly available. For reducing the mass of the flywheel we can change the shape of the flywheel in different shapes such as rectangular shape, parabolic and triangular shape.

Material should be selected such that they are having different density varying from 2000-9000 Kg/m3. Materials such as Gray Cast Iron, Cast Alloy Steel, Aluminium Alloy and Maraging Steel.

i) Different Shapes of flywheel

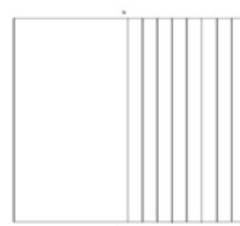

Fig 7(a) - Rectangular shape

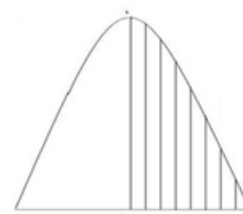

Fig 7(b) - Parabolic shape

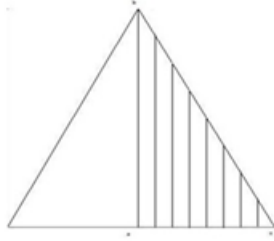

Fig 7(c) - Triangular shape

Calculated the volume of the 3 different geometries. Rectangular volume calculated by multiplication of area and thickness. Parabolic volume calculated by $y = ax^2 + bx + c$ while

triangular shape calculated as $y = mx + c$.

Table 3- Comparison of shapes

Shape	Rectangular	Parabolic	Triangular
Volume (cm ³)	1700	921.529	287.952

From above comparison table, we can say that the volume occupied but the triangular shape is much lesser than the other two shapes. Hence triangular shape can store the same amount of energy as regular shape stores. Therefore by reducing the shape, we can easily reduce the mass and cost of flywheel.

ii) Optimization of material

We are used four different materials having density

varying from 2000- 9000 Kg/m³. In optimization we made a program to find the maximum angular velocity and mass of flywheel which can bear stress without failure or deformation in shapes. This program is made in MATLAB.

```

vol=input('\n enter the volume of geometry=');

r=input('\n enter the radius of flywheel=');

sut=input('\n enter the ultimate strength of material=');
fos=input('\n enter the factor of safety=');
n=input('\n enter the value of n=');
q=input('\n enter the density of material=');
m=vol*q;
fprintf('\n the mass of flywheel is m=%f',m);
v=input('\n enter the poission ratio=');
e=(0.002742*vol*r*n^2*q);
fprintf('\n the value of e is e=%f',e);
em=e/m;
fprintf('\n the value of specific energy is em=%f',em);
s=((0.010968*q*r^2*n^2)*(v+3)/8);
fprintf('\n the value of stress is s=%f',s);
sall=(sut/fos);
fprintf('\n the value of allowable stress is sall=%f',sall);
while (s<sall)
n=n+25
e=(0.002742*vol*r*n^2*q)
fprintf('\n the value of e is e=%f',e);
em=e/m
fprintf('\n the value of specific energy is em=%f',em);
s=((0.010968*q*r^2*n^2)*(v+3)/8)
fprintf('\n the value of stress is s=%f',s);
end
    
```

X. RESULT

TABLE 4. RESULTS

Sr. No.	Material	Density (Kg/m ³)	Rotational speed (rpm)	Sp. Energy, ΔE/m (kJ/kg)	Actual mass, m (Kg)	Case 1 (Rectangular)	Case 2 (Parabolic)	Case 3 (Triangular)
						Mass, m (Kg)	Mass, m (Kg)	Mass, m (Kg)
1	Gray CI	7100	4000	4.387	11.78	12	6.00	2.044
2	Al Alloy	2700	4000	4.387	9.623	4.6	2.48	0.77
3	Cast alloy steel	7300	4000	4.387	11.78	12.41	6.72	2.102
4	Maraging Steel	8000	4000	4.387	11.79	13.6	7.37	2.304

Table 4 shows that, at same speed and same specific energy storage mass of flywheel is lesser in case of the Aluminium Alloy. If we prefer the triangular shape of the flywheel its mass is only 0.77 kg which is too much less than the present mass of the flywheel. Hence Al Alloy is much better than the other three materials.

Graphs obtained from program

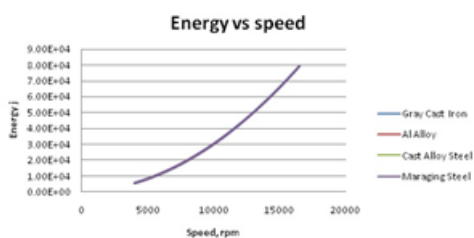

Fig.8 (a)

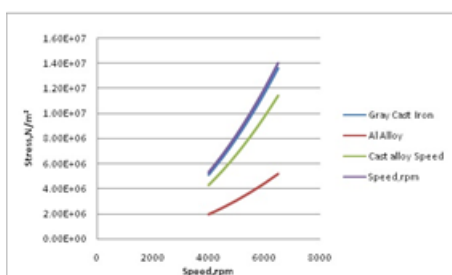

Fig.8 (b)

Fig. 8(a) shows the graph of speed vs energy. This shows that for all the materials, at same speed the energy stored by the flywheel is same for different mass of flywheel.

Fig. 8(b) shows the graph of speed vs stress. From this graph we can conclude that if we are going to increase the speed of flywheel, there not much stresses induced in the red colour line i.e. Al Alloy.

XI. CONCLUSION

From the above program and plot 6 we can say that for same energy storage the volume of triangular profile is less as compared to rectangular and parabolic profile. From table we can say that for same specific energy (i.e.

energy stored per unit mass) Aluminium Alloy has less mass as compared to other material for triangular profile. From plot 8(a) and 8(b) we can say that less stresses are induced in Aluminium alloy for same speed among all four materials for all three profiles. Hence we can conclude that Aluminium alloy is best material with triangular profile.

REFERENCES

- [1] Mr. Balasaheb S. Rathod, “Design and Analysis of Flywheel for Shape Optimization”, International Journal of Science and Engineering Invention (IJSEI) Volume 02 Issue 09, page no. 83-86, December 2016
- [2] Aswin Inbaraj Jaison, “Design and Optimization of Flywheel for Automobile Applications”, International Journal of Mechanical Engineering and Research, ISSN 0973-4562 Vol. 5, 2015.
- [3] Sushama G Bawane, ” Analysis and Optimization of Flywheel”, International Journal of Mechanical Engineering and Robotics Research, ISSN 2278 – 0149, Vol. 1, No. 2, July 2012.
- [4] Nitin Mohalkar, “Design and Analysis of Flywheel for Weight Optimization”, International Journal for Scientific Research & Development| Vol. 4, Issue 05, 2016.
- [5] Cook R.D, Malkus D.S, Plesh M.E. “Concepts and applications of Finite Element Analysis”, Wiley International, 3rd Edition, 1985.
- [6] S K Choudhary -"Design and Optimization of Flywheel" - A Past Review| IJMERR/Vol.1, Issue. XII/ pp.1-4, June 2012.

