

Visualization of an Audio Signal in Communication System

¹Anita Mohanty, ²Subrat Kumar Mohanty, ³Bhagyalaxmi Jena

^{1,3}Silicon Institute of Technology, Bhubaneswar

²College of Engineering, Bhubaneswar

Abstract— Speech and sounds are important sources of information in our everyday life for communication with our environment. In the internet age information circulates at an increasingly vertiginous rate. Data, photos, music and videos are continuously exchanged through communication networks. Communication is the process of establishing connection or link between two points for information exchange. Different communication equipments when assembled together form a communication system. The message or information communicates in the communication system may be codes, symbols, audio signals etc. An audio signal is a representation of sound which have frequencies in the audio frequency range of 20Hz to 20KHz. Basically, this paper demonstrates AM, FM and PM analog modulation using real audio signal contained in .wav file by using LABVIEW. An interface is constructed that allows users to choose the different modulation and also allows varying the amplitude, frequency, phase, frequency modulation index and phase modulation index.

Keywords- communication, modulation, modulation index, sinals, LABVIEW

I. INTRODUCTION

Communication is the process of establishing a connection or link between two points for information exchange. It may also the process of conveying message or exchanging information at a distance. Communication involves the transmission of information from one point to another through the following process. Generation of a pattern or image of an originator [1,2] follows the steps such as description of that image, encoding of symbols in a recognizable form suitable for transmission, transmission of the encoded symbols, decoding and reproduction of the original symbols and then recreation of the original pattern or image.

The communication system serves to communicate a message or information. This message or information originates in the information source may be in the form of words, code, symbols, audio signals etc. An audio signal is a representation of sound which has audio frequency range from 20Hz to 20KHz.

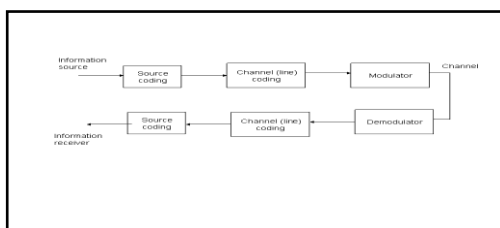

(Fig.1 Block diagram of communication system)

LABVIEW (short for Laboratory Virtual Instrumentation Engineering Workbench) is a platform and development environment for a visual programming language from National Instruments. It has a block diagram and front panel [1,2].To build programs simply dragging and dropping the virtual representation of the lab equipments.

II. LITRATURE SURVEY FOR ANALOG COMMUNICATION TECHNIQUES

Depending upon the message signal communication may classified as

- Analog communication
- Digital communication

Here in this paper only the analog communication techniques are used to visualize an audio signal. Here the carrier and audio signal inputs enters the three AM, FM and PM formula nodes and each outputs the different modulated signals. The case structure allows selecting which modulated signal to plot on the waveform chart by using LABVIEW.

MODULATION PROCESS:

In communication the message signal is transmitted from information source to the destination. The transmitter modifies the message signal into a form which is suitable for transmission over a channel. This modification is achieved by means of a process known as modulation. Modulation may be defined as the process by which some characteristics of carrier signal is varied in accordance with the instantaneous value of the modulating signal. The signal containing the information is known as modulating signal or baseband signal. The carrier frequency is greater than the modulating frequency. The signal resulting from the process of modulation is called modulated signal [2,6].

The analog modulations used here are the AM (Amplitude Modulation), FM (Frequency Modulation), PM (Phase Modulation).

AMPLITUDE MODULATION:

Amplitude modulation may be defined as a system in which the maximum amplitude of the carrier wave is made proportional to the instantaneous value (amplitude) of the modulating or baseband signal.

The standard equation for amplitude modulated (AM) wave may be expressed as $s(t) = x(t) \cos \omega_c t + A \cos \omega_c t$

$$s(t) = [A + x(t)] \cos \omega_c t$$

$$c(t) = A \cos \omega_c t$$

Where, $c(t)$ is a carrier wave
 $x(t)$ is modulating signal

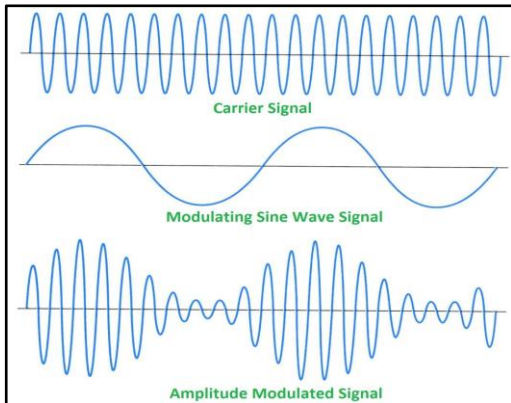

(Fig2. Amplitude modulation)

FREQUENCY MODULATION:

Frequency Modulation (FM) is a form of modulation in which changes in the carrier wave frequency correspond directly to changes in the baseband signal. FM is considered an analog form of modulation because the baseband signal is typically an analog waveform without discrete, digital values. If the information to be transmitted (i.e., the base band signal) is $x_m(t)$ and the sinusoidal carrier is $x_c(t) = A_c \cos(2\pi f_c t)$, then the frequency modulated output is

$$y(t) = A_c \cos\left(2\pi \int_0^t f(\tau) d\tau\right)$$

$$= A_c \cos\left(2\pi \int_0^t [f_c + f_\Delta x_m(\tau)] d\tau\right)$$

$$= A_c \cos\left(2\pi f_c t + 2\pi f_\Delta \int_0^t x_m(\tau) d\tau\right)$$

After simplifying the equation will be

$$y(t) = A_c \cos\left(2\pi f_c t + \frac{f_\Delta}{f_m} \cos(2\pi f_m t)\right)$$

where f_Δ is the frequency deviation.

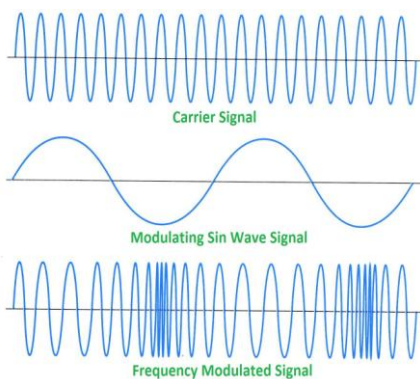

(Fig.3 Frequency Modulation)

PHASE MODULATION:

Phase modulation (PM) is a modulation pattern that encodes information as variations in the instantaneous phase of a carrier wave. PM changes the phase angle of the complex envelope in direct proportion to the message signal.

Suppose that the signal to be sent (called the modulating or message signal) is $m(t)$ and the carrier onto which the signal is to be modulated is $c(t) = A_c \sin(\omega_c t + \phi_c)$

This makes the modulated signal as

$$y(t) = A_c \sin(\omega_c t + m(t) + \phi_c)$$

This shows how $m(t)$ modulates the phase - the greater $m(t)$ is at a point in time, the greater the phase shift of the modulated signal at that point. It can also be viewed as a change of the frequency of the carrier signal, and phase modulation can thus be considered a special case of FM in which the carrier frequency modulation is given by the time derivative of the phase modulation.

The modulation signal could here be

$$m(t) = \cos(\omega_c t + k\omega_m(t))$$

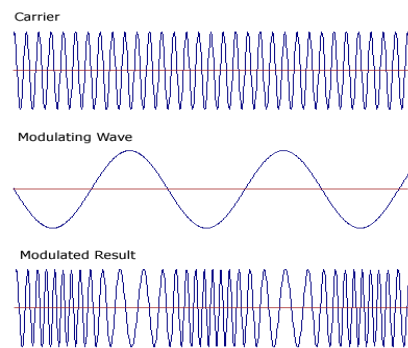

(Fig4. Phase modulation)

III. PROPOSED WORK BY USING LABVIEW

In this LABVIEW program there is a front panel and a block diagram panel. In front panel there are three numeric controls for amplitude, frequency and phase. For audio file input control use the file path control which can be found in modern, silver and also in the classic control pallet of the front control panel.

The block programming panel consists mainly of numeric inputs (amplitude, frequency, phase, index constants), the file importing function element, three formula nodes, a case structure, a waveform chart, timer and stop. All these functional elements are embedded inside the while loop.

The carrier and audio signal inputs enters the three AM, FM and PM formula nodes and each outputs the different modulated signals. The case structure allows

selecting which modulated signal to plot on the waveform chart.

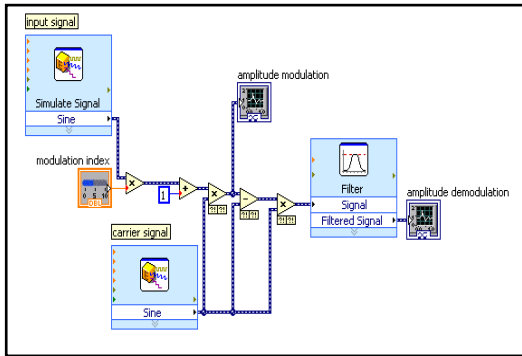

(Fig.5 AM Design in LABVIEW)

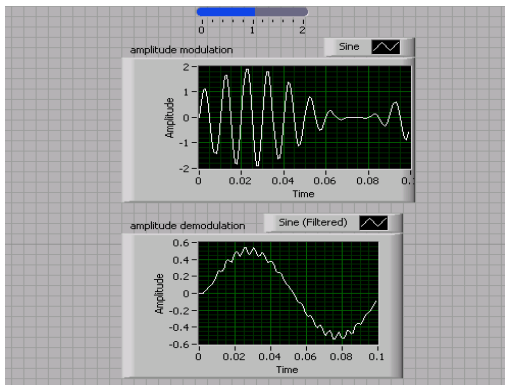

(Fig.6 AM Simulation Result)

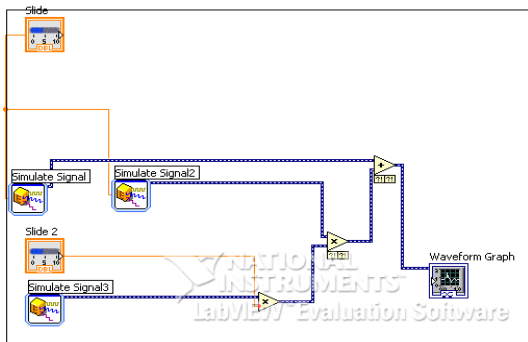

(Fig. 7 FM Design in LABVIEW)

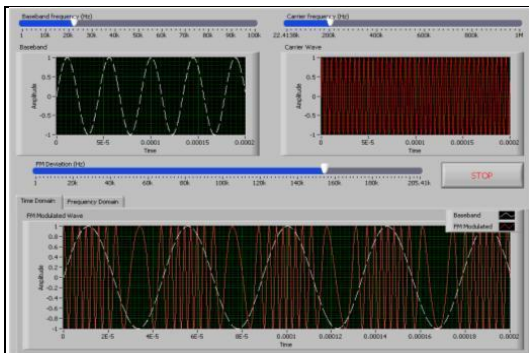

(Fig.8 FM Simulation Result)

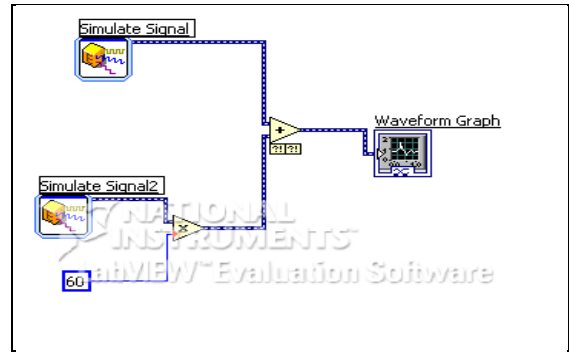

(Fig.9 PM Design in LABVIEW)

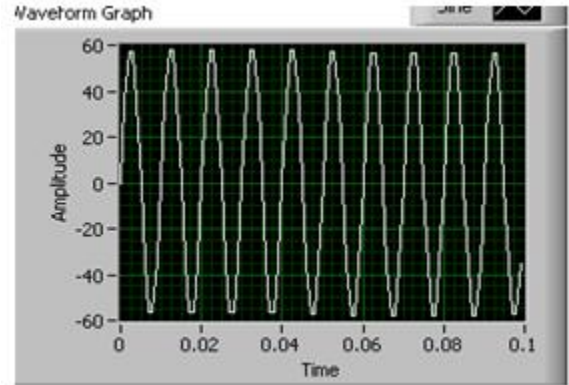

(Fig.10 PM Simulation Result)

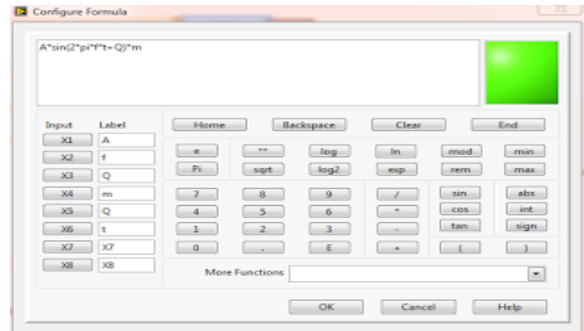

(Fig.11 AM Formula Node)

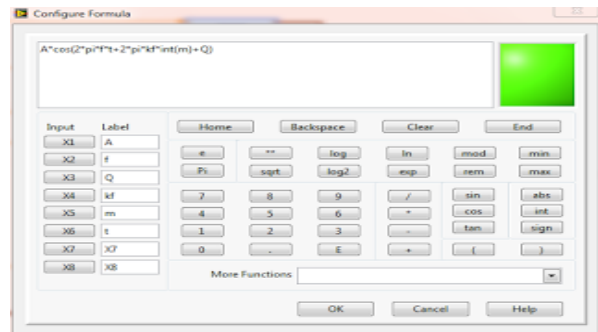

(Fig.12 FM Formula Node)

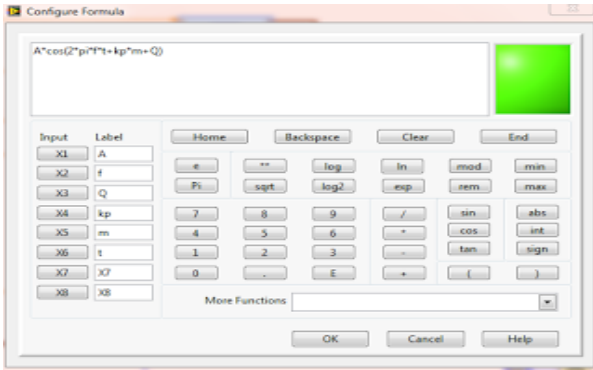

(Fig.13 PM Formula Node)

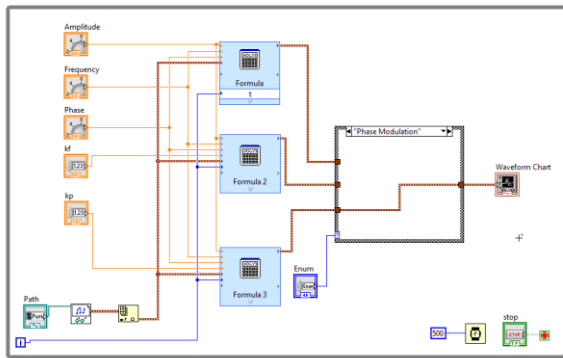

(Fig. 14 Analog Modulation Design in LABVIEW for Visualizing an Audio Signal)

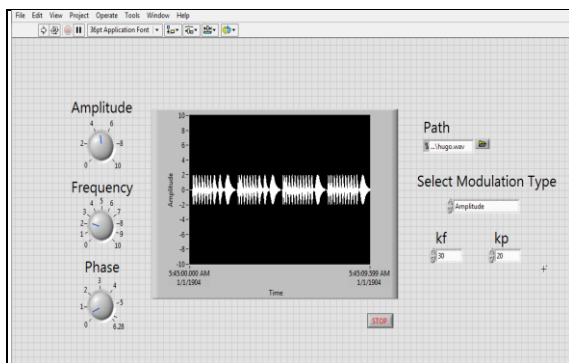

(Fig. 15 Simulation Result)



IV. CONCLUSION

From this paper it is concluded that some of the analog communication techniques have explored by using LABVIEW and its scope in visualizing an audio signal in wav format and close simulation of these systems. So that even people with limited coding experiences can write programs and deploy simulation tests in a reduced time frame when compared to more conventional or competing system.

REFERENCES

- [1]. Learning with LabVIEW 7TM EXPRESS- Robert H. Bishop
- [2]. Sanjay Sharma, "Communication Systems (Analog & Digital)", S.K. KATERIA & SONS, 4th Ed,2007.
- [3]. "Product Activation FAQ", National Instruments.
- [4]. "Building a Stand-Alone Application", National Instruments.
- [5]. "Using the Lab VIEW Run-Time Engine", National Instruments.
- [6]. S. Tretter, Communication System Design Using DSP Algorithms, Klumer Academic/Plenum Publishers, 2003.
- [7]. N. Kehtarnavaz and N. Kim, Digital Signal Processing System-Level Design Using LabVIEW, Elsevier, 2005.
- [8]. National Instruments, LabVIEW User Manual, Part Number 320999E-01, 2003.
- [9]. N. Kehtarnavazand C.Gope, "DSP System Design Using Lab view and Simulink : A Comparative Evaluation," Proceedings of ICASSP, vol. 2, 2006, pp. 985-988.